

September 2021

The Effect of the Marketing Mix of MSME Products on Sales Volume During the Covid-19 Pandemic

murdayani murdayani

Universitas Bhayangkara Jakarta Raya, murdayanie@gmail.com

Beti Nurbaiti

Department of Management Science, Postgraduate Program, Faculty of Economics and Business, University Of Indonesia, bettysigit@gmail.com

Soehardi Soehardi

Bhayangkara University, Greater Jakarta, soehardi@dsn.ubharajaya.ac.id

Follow this and additional works at: <https://scholarhub.ui.ac.id/jsgs>



Part of the [Economics Commons](#), [Feminist, Gender, and Sexuality Studies Commons](#), [International and Area Studies Commons](#), [Islamic Studies Commons](#), [Terrorism Studies Commons](#), and the [Urban Studies Commons](#)

Recommended Citation

murdayani, murdayani; Nurbaiti, Beti; and Soehardi, Soehardi (2021) "The Effect of the Marketing Mix of MSME Products on Sales Volume During the Covid-19 Pandemic," *Journal of Strategic and Global Studies*: Vol. 4 : No. 2 , Article 3.

DOI: 10.7454/jsgs.v4i2.1043

Available at: <https://scholarhub.ui.ac.id/jsgs/vol4/iss2/3>

This Article is brought to you for free and open access by the School of Strategic and Global Studies at UI Scholars Hub. It has been accepted for inclusion in Journal of Strategic and Global Studies by an authorized editor of UI Scholars Hub.

The Effect of the Marketing Mix of MSME Products on Sales Volume During the Covid-19 Pandemic

Murdayani*¹, Beti Nurbaiti², and Soehardi³

^{1,2,3} Department of Management Science, Graduate Program, Faculty of Economics and Business, Bhayangkara University, Indonesia

ABSTRACT

This study aims to find out how much influence the marketing mix strategy has on sales volume during the Covid-19 pandemic on culinary MSMEs located in the North Bekasi area. The population is all culinary MSMEs in the North Bekasi area amounting to 1060 actors and sampling methods in the cluster sampling area of North Bekasi amounted to 104 MSMEs. The author uses quantitative methods using SEM (Structural Equation Modeling) and data analysis used with the Lisrel 8.70 software program. For primary data obtained through Likert scale with validity, reliability and GOFI test. From the results of the study obtained the conclusion that the quality of products, prices and location has no effect on sales volume, only promotional variables that positively affect the sales volume of culinary MSMEs with micro criteria in North Bekasi

Keywords: Product Quality, Price, Location, Promotion, and Sales Volume.

1. Introduction

Micro, Small and Medium Enterprises (MSMEs) are businesses that have an important role in economic sustainability in Indonesia because MSMEs are productive and always growing businesses and become one of the driving forces of national economic development. Indonesia is currently experiencing a Covid-19 pandemic. Covid-19 has had a major impact on all aspects of life and all regions of the country. The impact felt by a country is related to the economic sector and micro, small and medium enterprises (MSMEs). In implementing good marketing, micro, small and medium enterprises must pay attention to the marketing mix. This is important because the marketing mix is one of the main factors that consumers must consider when deciding to buy a product (Sudari et al., 2019). To determine which product to buy, this choice is influenced by several factors, including product quality, location, promotion, and price. Price is an important component of any marketing plan because the price determines the profit and profitability of the business (Musfar, 2020).

* Corresponding author : Murdayani
E-mail : murdayanie@gmail.com

From observations made by researchers during this pandemic, many sellers sell their wares by reducing the dose but not accompanied by a decrease in price. Another factor that affects the volume of purchases is location. In this North Bekasi area, with the increasing number of culinary traders, it creates problems for the surrounding environment, namely by the appearance of unorganized traders so that the environment looks untidy. In the North Bekasi area, there are still many culinary traders who do not do enough promotion in their sales, and there are still many micro-entrepreneurs who package food without considering health factors and are less attractive. The formulation of the problem that will be discussed in this study is whether there is an effect of product quality, price, location selection, and promotion on sales volume. This study aims to determine the effect of product quality, price, location selection, promotion on the sales volume of culinary-based SMEs during the Covid-19 pandemic in North Bekasi.

2. Literature Review

2.1. Small and Medium Micro Enterprises

Small and medium micro enterprises or in short MSMEs are productive business units that are independent, run by individuals or economic bodies in all sectors of the economy (Tambunan, 2014) According to (Dhewanto, 2019) that Law No. 20 of 2008 on MSMEs. Article 1 of the Act, stated:

- a. Micro Enterprise is a business owned by an individual or business entity that has a wealth of no more than 50 million rupiah and annual income of not more than 300 million rupiah.
- b. Kecil business is a business conducted by individuals or business entities that have a net worth above 50 million rupiah to 500 million rupiah and annual income above 300 million rupiah to 2.5 billion rupiah.
- c. Medium Enterprises are businesses conducted by individuals or business entities that have a net worth above 500 million rupiah up to 10 billion rupiah and annual income above 2.5 billion rupiah to 50 billion rupiah.

2.2. Covid-19 Pandemic

Pandemic covid-19, known as the Pandemic coronavirus, is coronavirus (Covid-19) caused by acute respiratory syndrome (SARS-CoV-2), the virus identified in December 2019 in Wuhan,

China. The pandemic was declared a public health emergency and international attention in January 2020 (Wikipedia, 2020).

According to the World Health Organization (WHO) in the study (Soehardi et al., 2020) the characteristics of covid-19 include shortness of breath, fatigue, dry cough, loss of sense of taste and fever. On March 11, 2020 it was announced by WHO that Covid-19 became a pandemic in all countries of the world. Covid-19 has been happening all over the world since March until August 2020.

2.3. Marketing Mix

Marketing is an activity carried out by a group of people or institutions to carry out the communication process, convey information and make offers for a product or service it owns (Tjiptono, 2020). In the marketing mix there are marketing strategies or references that can determine the best composition of the four components or marketing variables to achieve the target market and achieve the company's goals. Philip Kotler said these four variable elements are traditional formulas of marketing mix namely product, price, location, promotion (Kotler & Amstrong, 2012)

2.3.1. Product Quality

Products are everything in the form of goods or services offered to consumers (Assauri, 2019) In a product contained factors that consumers expect, among others: (1) Quality / quality; (2) Appearance, selection of goods; (3) Model/style; (4) Brand; (5) Packaging; (6) Size; (7) Type; (8) Warranties; and (9) the Services.

2.3.2. Price

Price is the amount that a consumer must pay for a product or service. In the price there are four indicators that characterize the price, this is put forward by (Kotler & Amstrong, 2012) namely affordable prices, prices comparable to product quality, competitive prices, prices that correspond to product excellence.

2.3.3. Promotion

Promotion is an activity to convey information to consumers in the hope that consumers are interested in what is offered (Philip, 2014). Promotion is a tool that plays a role to convey

information to consumers through means of communication. There are several dimensions in the promotional mix conveyed by (Kotler & Amstrong, 2012), among others: (1) Advertising; (2) Sales shall be conducted directly face-to-face to the consumer; (3) Promotion of sales by giving discounts or coupons to certain customers; and (4) Good relations with all components of the organization.

2.3.4. Location

What is meant by location is a place to conduct sales activities where a business is run. According to (Adiwijaya, 2010) there are several categories that can be used in determining strategic location, among others: (1) Sales position close to the office; (2) The place of sale is close to the target, if the place is easy to reach then it is said to be strategic; (3) A place that buyers can easily find; (4) Easy access to the place of sale. With such a strategic location will provide benefits for the sellers.

2.4. Sales volume

Sales volume is the company's achievement of the number of sales generated or the number of goods sold in the form of liters, kilos or units (Rangkuti, 2015) This sales volume refers to items sold within a certain period. Some efforts some efforts to increase sales volume according to (Kotler, 2012), among others: (1) Selling products in such a way that consumers can see it; (2) Arrange well so that the product attracts the attention of consumers; (3) Conduct market analysis; (4) Identify potential buyers; (5) Organizing exhibitions; (6) Conduct discount promotions.

3. Research Methods

3.1. Research place and time

This research was conducted in North Bekasi area to culinary MSMEs with micro criteria for a period of 4 months, namely in September to December 2020.

3.2. Sampling Method

The population in this study is culinary-based MSMEs with micro-business criteria located in the North Bekasi area. According to the data obtained from the Office of SME Cooperatives Bekasi city obtained MSMEs data assisted in the city of Bekasi there are 1581 micro-businesses consisting of 1060 culinary-based MSMEs and 521 non-culinary MSMEs (Dinkop, 2020). In

this case researchers want to conduct research only on culinary MSMEs with micro criteria. According to (Sugiyono, 2017) the sample is a small part of the population taken according to certain rules that can represent its population. The sample is also defined as a representative of population (Echdar, 2017) In this study the method to take research samples was conducted by cluster sampling technique which is a way of sampling based on a particular cluster. In this study the author wanted to take samples from culinary MSMEs with micro business criteria located in the North Bekasi area and there are 104 culinary business actors.

Table 3.1. Number of MSMEs in Bekasi

NO	DISTRICT	UMKM CULINARY
1	Bantar Gebang	30
2	West Bekasi	92
3	South Bekasi	172
4	East Bekasi	210
5	North Bekasi	104
6	Sempurna Teak	29
7	Jatiasih	81
8	Medan Satria	40
9	Mustikajaya	60
10	Pondok Gede	125
11	Jasmine Cottage	55
12	Rawalumbu	62
AMOUNT		1060

3.3. Data Retrieval Techniques

In this study, several data retrieval techniques were used, including primary and secondary data.

1. Primary data consists of field studies, observations, interviews, questionnaires and understanding:
 - a. Field studies, finding and obtaining data from culinary MSMEs as respondents who will later be careful authors.
 - b. Observation, an activity that researchers do with direct observation to get information on respondents and learn various things related to research.

- c. Interviews, researchers conduct data collection with communication techniques face-to-face to find out the problems faced by the source that the researcher will ask into question.
 - d. Questionnaire, the author asked several questions to respondents, namely culinary MSMEs in North Bekasi with the spread of questionnaires that serve to obtain information by using a Likert scale with a scale of 1 to 4.
2. Secondary data in this study can be obtained from the speaker of one of the employees who work in the Office of SME Cooperatives Bekasi and the author conducted a live interview by visiting the office of the Office of SME Cooperatives Bekasi on October 23, 2020, from books and the internet.

3.4. Data Analysis Methods

Data analysis used in this study using SEM (Structural Equation Modeling) with Lisrel software program (Linear Structural Relationship) 8.70. Researchers use Lisrel 8.70 software because in addition to the many respondents, 104 respondents will also give very valid results because the tools are able to several different stages of data processing in other software in the same test.

3.4.1. Validity Test

Test the construct validity in this study using SEM with Lisrel 8.70 software. A variable is said to have validity if the Loading Factors are greater than the critical value ≥ 1.96 and Standardized Loading Factors ≥ 0.70 .

3.4.2. Reliability Test

In this case, the test is reliable to determine the consistency of the answers to an instrument that measures the concept and functions to access the "goodness" of the measurement.

3.4.3. Match Test / GOFI

In evaluating the level of data compatibility with the model is done through several stages, namely Overall Model Fit (Overall Model Fit), measurement model match (Measurement Model Fit), structural model fit (Structural Model Fit). According to (Wijanto, 2008) to evaluate the suitability of the model thoroughly classify the suitability of the model as follows:

Table 3.2. Details of 9 Goodness of Fit Index (GOFI) indicators

Indicator GOFI	GOFI Indicator Description	Standard Values for Good Matches
RMSEA	Root Mean Square Error of Approximation	≤ 0.08
NFI	Normed Fit Index	≥ 0.90
NNFI	Non-Normed Fit Index	≥ 0.90
CFI	Comparative Fit Index	≥ 0.90
IFI	Incremental Fit Index	≥ 0.90
RFI	Relative Fit Index	≥ 0.90
Hours. RMR	Standardized Root Mean Square Residual	≤ 0.05
GFI	Goodness of Fit Index	≥ 0.90
AGFI	Adjusted Goodness of Fit Index	≥ 0.90

Source: Wijanto, 2008

A variable has a good validity against a construct or latent variable if the Standardized Loading Factor (SLF) value ≥ 0.50 . A good Construct Reliability is if the Construct Reliability (CR) value ≥ 0.70 and the Extract Variant (VE) ≥ 0.50 . The formula used is as follows:

$$CR = \frac{(\sum \text{Standardized Loading})^2}{(\sum \text{Standardized Loading})^2 + \sum \text{Error}}$$

$$VE = \frac{\sum \text{standardized Loading}^2}{n}$$

Where N is the number of variables observed.

Fit model / structural model with a significance level of 0.05, then the t value of the structural equation should be ≥ 1.96 . Hypotheses are accepted if the absolute value of t (t-value) ≥ 1.96 , and the coefficient of t value (either positive or negative) matches the relationship between the variables listed in the research hypothesis.

4. Results and Discussion

The results of the following data processing show that all the latent variables of the study with their indicators have good compatibility, good validity and good reliability.

4.1 Latent Variable Product Quality (PROD)

In conducting the measurement model test, the researcher conducted two tests, namely when the pretest was carried out on 20 respondents as samples with statements of exogenous latent variables of Product Quality, then in the core study consisted of 104 samples with 6 (six) statements of each observed variable, (denoted by PROD).

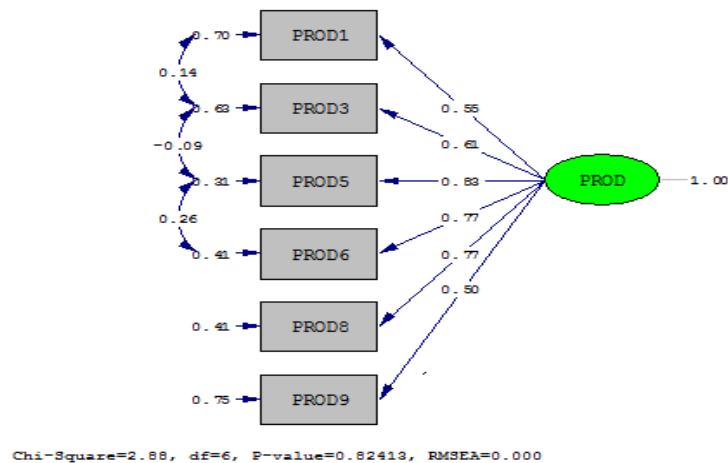

Figure 4. 1 Prod latent Variable Measurement Model Test

In distributing the product quality variable questionnaire, 6 (six) indicators were proposed. The magnitude of the load on the packaging indicator factor with the brand is (0.83) indicating that this subfactor is the most dominant in the product quality variable. The next indicator is the magnitude of the load (0.77) where there are 2 (two) sub-factors namely packaging by displaying identity and popular/current food, these two sub-factors produce the same amount of load. Then for the goods option indicator of (0.61) which states that the food products sold by SMEs are varied. The next indicator is the characteristics of the product with the magnitude of the load (0.55), that MSME actors in selling their wares have certain characteristics where the food is different from other sellers. Furthermore, the quality and packaging indicator is (0.50) where this indicator is at the lowest level, namely food packaging that protects from damage and dirt.

4.2 Variable Latent Price (HAR)

In the measurement model test, two tests were carried out, namely at the pretest to 20 samples with statements of the price exogenous latent variable and in this core study there were 104 samples with 4 (four) statements of each variable being observed (denoted by HAR).

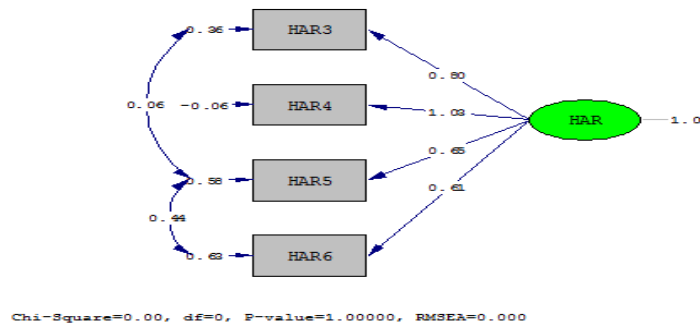

Figure 4.2 Har Latent Variable Measurement Model Test

In distributing the price variable questionnaire, 4 (four) indicators are proposed, namely price affordability, price suitability, competitive prices, and price determination. The magnitude of the load on the price suitability indicator factor is (1.03) and (0.80) indicating that this subfactor is the most dominant in the price variable. That the MSME actors provide a price that is in accordance with the dose and the price given is in accordance with the quality and taste of the food sold. The next indicator is the amount of cargo (0.65), namely the price given is in accordance with the expectations of the buyer, meaning that MSME actors provide affordable prices to consumers. Then for the lowest indicator of (0.61).

4.3 Latent Variable Promotion (PROM)

In conducting the measurement model test, two tests were carried out, namely the pretest test on 20 samples with statements of the promotion exogenous latent variable, and tests on the core research on 104 samples, with 3 (three) statements of each variable being observed (denoted by PROM).

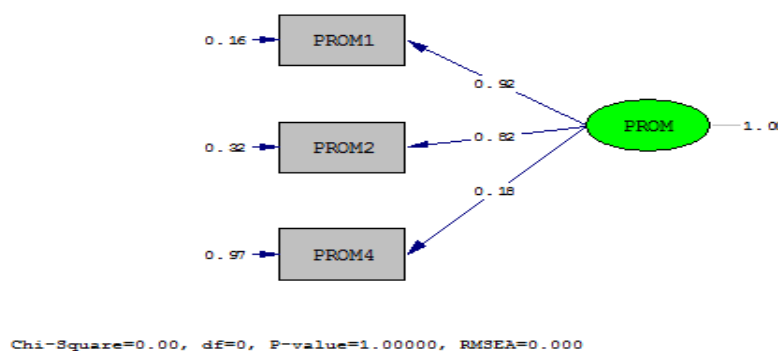

Figure 4.3 Prom Latent Variable Measurement Model Test

In distributing the promotion variable questionnaire, 3 (three) indicators were proposed. The magnitude of the load on the advertising indicator factor is (0.92), indicating that this sub-factor is the most dominant in the promotion variable. The next indicator is the magnitude of the load (0.82) which is to provide a sign or nameplate at the place of sale. Then for the next indicator

it produces a payload (0.18), namely MSME actors in carrying out promotions by providing coupons/bonuses to certain customers.

4.4 Latent Variable Location (LOK)

In carrying out the measurement model test, two tests were carried out, namely the pretest test on 20 samples with the statement of the exogenous latent variable Location, and the test on the core research on 104 samples, with 3 (three) statements of each variable being observed (denoted by LOK).

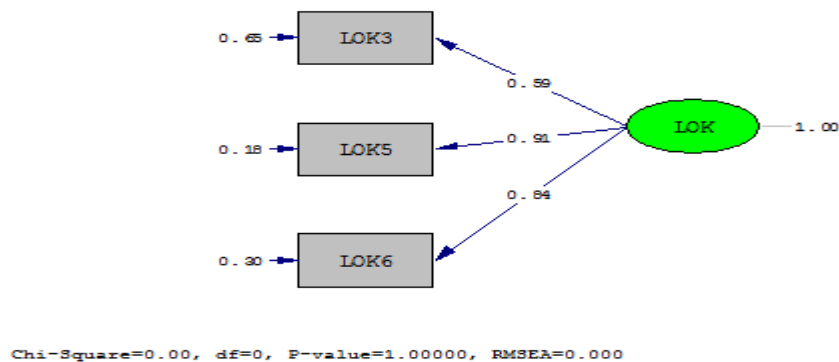

Figure 4.4 LOK Latent Variable Measurement Model Test

In distributing the location variable questionnaire, 3 (three) indicators were proposed. The magnitude of the load on the safe location indicator factor is (0.91) indicating that this subfactor is the most dominant in the location selection variable. The next indicator is the magnitude of the load (0.84), which is a location that provides a parking space, meaning that MSME actors in choosing a location provide a parking space. Then for the lowest indicator of (0.59), namely the location of the sale which is in the place of culinary traders.

4.5 Variable Latent Sales Volume (VOL)

In carrying out the measurement model test, two tests were carried out, namely the pretest test on 20 samples with statements of the endogenous latent variable Sales Volume, and tests on the core research on 104 samples, with 6 (six) statements of each variable observed (denoted by VOL).

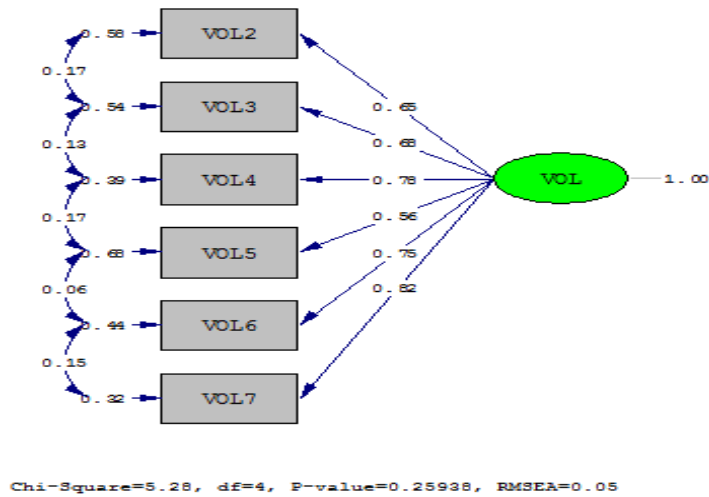

Figure 4. 5 Latent Variable Measurement Vol Test

4.6 Confirmatory Factor Analysis (CFA) Test

Confirmatory Factor Analysis Test is a test by analyzing the CR value (critical ratio) and P value (probability) with the required statistical limits, which are above 1.96 for the CR value and below 0.05 for the P value.

The results of the analysis of data processing show that the construct used to form a research model, in the confirmatory factor analysis process, has met the goodness of fit criteria that have been set. The probability value of the goodness of fit test shows a value of 0.00000 (< 0.05), and RMSEA 0.000 (0.00). The results of the other model fit tests can be seen in the table below.

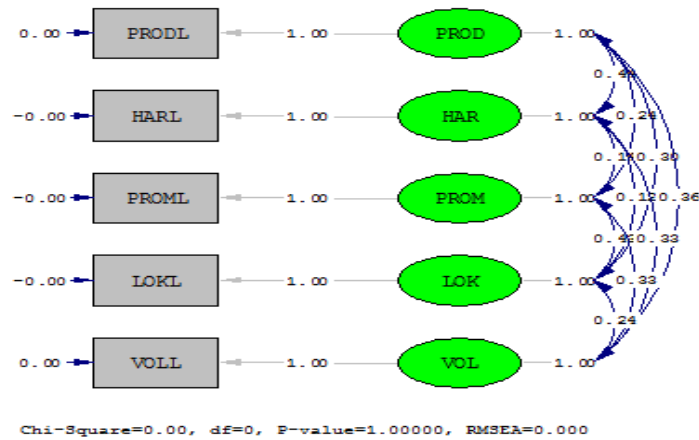

Figure 4. 6 Confirmatory Model Test

4.7 Structural Model Test / Research Hypothesis Test

After the researchers tested the overall fit of the model, the next step was to test the research hypotheses on the structural model. Model testing is done to find out how the influence of the variables Product Quality, Price, Promotion and Location on sales volume. With this test, it will be known whether the hypothesis of the research model is accepted or rejected.

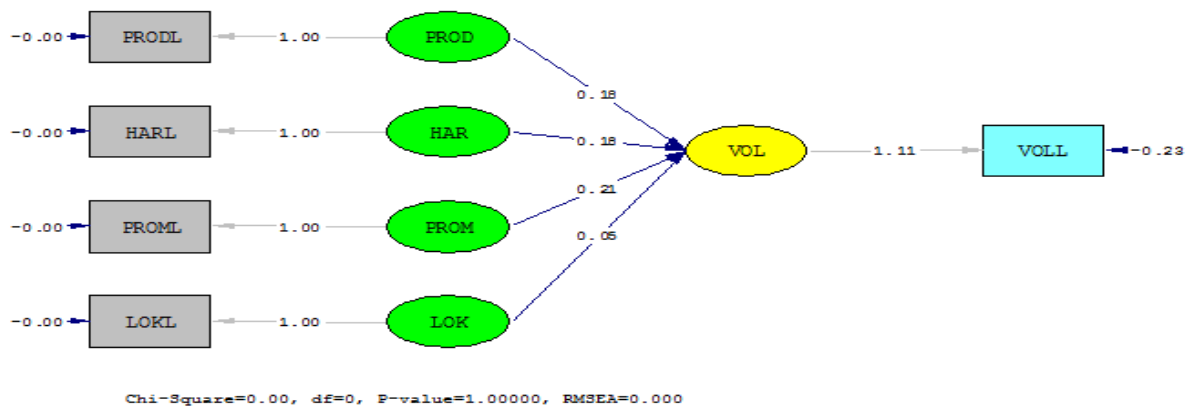

Figure 4. 7 Standardized Solution Structural Model Test

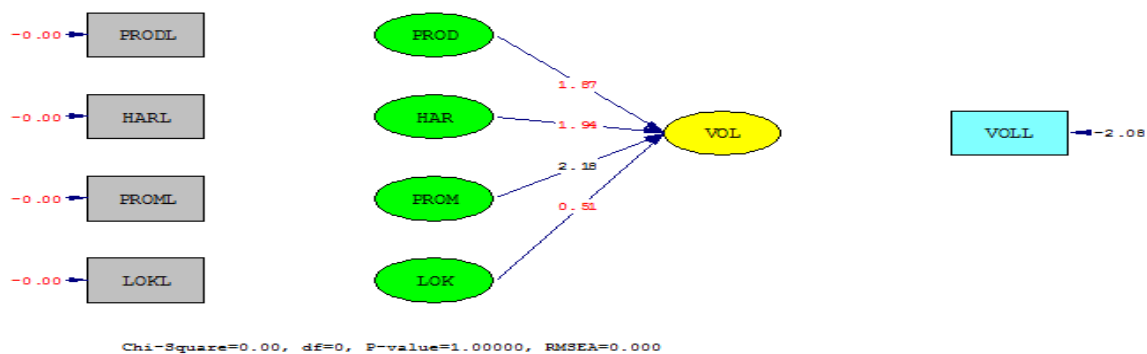

Figure 4. 8 T-Value Structural Model Test Results

Table 4. 1 Result of Structural Model Test / Research Hypothesis Test

Relationships/Influences Between Latent Variables	Calculated T value	Standard Coefficient	Conclusion of Hypothetical Significance Test Results
H1: There is a positive relationship/influence between latent variables PROD (Product Quality) to VOL (Sales Volume)	1.87	0.18	H1 is rejected, because the value of $t < 1.96$, there is no relationship or influence between PROD and VOL
H2: There is a positive relationship/influence between	1.94	0.18	H2 is rejected, because of the value of $t < 1.96$, there is no relationship or

Relationships/Influences Between Latent Variables	Calculated T value	Standard Coefficient	Conclusion of Hypothetical Significance Test Results
latent variable HAR (Price) to VOL (Sales Volume)			influence between HAR to VOL.
H: There is a positive relationship/influence between latent variables PROM (Promotion) to VOL (Sales Volume)	2.18	0.21	H3 accept, value $t > 1.96$, there is a positive relationship / influence between PROM to VOL.
H4: There is a positive relationship/influence between latent variable LOK (Location) to VOL (Sales Volume)	0.81	0.05	H4 was rejected, because of the value of $t < 1.96$, there was no relationship or influence between LOK to VOL.

Source: Research Data Processing Results (2021)

5. Conclusion

This research has been conducted in North Bekasi sub-district where the object of research is the culinary-based MSMEs with micro business criteria as many as 104 people. This study aims to measure whether there is a significant influence between product quality variables, price, promotion and location on sales volume variables. Based on the results of the study and discussion obtained, researchers can draw the following conclusions:

- a. The latent variable of product quality has no effect on sales volume, meaning that even if a product is getting better or not, it does not really affect and does not have an impact on sales volume. The most dominant indicator in this study is packaging by showing brand and identity compared to other indicators, namely packaging that protects from damage.
- b. The price latent variable has no effect on sales volume, meaning that even though a higher or lower price does not really affect and does not have an impact on sales volume. The most dominant indicator in this study is price suitability.
- c. Promotion latent variables have a significant effect on sales volume, meaning that the more often MSMEs do promotions, the more they will increase sales volume. The most dominant indicator in this study is advertising by placing banners compared to other indicators, namely the provision of discounts or coupons.
- d. Location latent variable has no effect on sales volume, so location conditions do not really affect and do not have an impact on sales volume. The most dominant indicator

in this study is a safe location compared to other indicators, namely the location of sales in the area of culinary traders.

6. Suggestion

Based on these conclusions, from this study several suggestions can be given in increasing sales volume to MSME players in North Bekasi:

- a. Because of the lack of MSME actors to knowledge about promotion with digital technology in this case to the Bekasi city government should work with stakeholders of MSMEs owners to conduct training activities and competencies expertise in the field of digital marketing, about product quality and marketing.
- b. Seeing the positive influence of promotion on sales volume, promotional activities should be further optimized so that the merchandise will be better known in the community at large, so that sales turnover will increase.

Reference

- Adiwijaya, M. (2010). *8 Jurus Jitu Mengelola Bisnis Ritel Ala Indonesia*. PT Alex Media Komputindo.
- Assauri, S. (2019). *Manajemen Pemasaran Dasar, Konsep dan Strategi* (1st-Cet 17th ed.). PT Rajagrafindo Persada.
- Dhewanto, W. (2019). *Internasionalisasi UKM Usaha kecil dan Mikro Menuju Pasar Global* (Aditya Ari Christian (ed.); I).
- Echdar, S. (2017). *Metode Penelitian Manajemen Dan Bisnis* (I). Ghalia Indonesia.
- Kotler & Amstrong. (2012). *Prinsip-prinsip Pemasaran* (13th ed.). Erlangga.
- Musfar, T. F. (2020). *Buku Ajar Manajemen Pemasaran* (I). CV. Media Sains Indonesia.
- Rangkuti, F. (2015). *Personal SWOT Analysis*. PT Gramedia Pustaka Utama.
- Soehardi, Siddha, A., Hardiyono, Siswanti, T. dan, & Hardpamungkas, N. E. (2020). Pengaruh pandemik covid-19 terhadap wisatawan mancanegara dan nusantara serta karyawan perusahaan penerbangan di indonesia. *Jurnal Ilmiah Manajemen*, 2(2), 3–4.
- Sudari, S. A., Tarofder, A. K., Khatibi, A., & Tham, J. (2019). Measuring the critical effect of marketing mix on customer loyalty through customer satisfaction in food and beverage products. *Management Science Letters*, 9(9), 1385–1396. <https://doi.org/10.5267/j.msl.2019.5.012>
- Sugiyono. (2017). *Metode Penelitian Kuantitatif, Kualitatif dan R&D*. Bandung: PT Alfabet. In *Sugiyono. (2017). Metode Penelitian Kuantitatif, Kualitatif dan R&D. Bandung: PT Alfabet.*
- Tambunan, T. (2014). *UMKM INDONESIA*. Usakti.
- Tjiptono, F. (2020). *Pemasaran* (F. Tjiptono (ed.); I). CV. Andi Offset.
- Wijanto, S. H. (2008). *Struktural Equation Modeling Dengan Lisrel 8.8*. Graha Ilmu.