

Overheat Protection for Motor Crane Hoist Using Internet of Thing

by mdocument8 1

Submission date: 21-Sep-2021 09:38PM (UTC-0500)

Submission ID: 1615266949

File name: 0_Final_Version_IJCAT-3842151069710001000.pdf (848.75K)

Word count: 6516

Character count: 33916

Overheat Protection for Motor Crane Hoist Using Internet of Thing

Paduloh Paduloh* and
Rifki Muhendra

Industrial Engineering Study Program,
Engineering Faculty,
Bhayangkara Jakarta Raya University,
Bekasi, Indonesia
Email: paduloh@dsn.ubharajaya.ac.id
Email: rifki.muhendra@dsn.ubharajaya.ac.id
*Corresponding author

Abstract: Crane hoist is a material moving tool and work tool for the production process. The hoist often stops suddenly due to overheating. This condition impacts the production process and safety. This study aims to design a safety device to anticipate the overheating in the hoist. The research began with brainstorming, prioritizing AHP and designing products using QFD, and designing systems using UML. The product is designed to use a microcontroller, Arduino, fan, and GSM to control the motor temperature and transmit temperature information to the user. The motor cooler will operate if there is a notification of a motor temperature rise. The novelty of this research lies in the decision-making system, product design, and information system design. Thus, this research can produce a safety device that suits company needs, is easy to operate, and prevent overheating effectively.

Keywords: Hoist Crane, QFD, UML, Arduino, IoT

Reference to this paper should be made as follows:

Biographical notes: Paduloh is a Doctor of Engineering from IPB University from Agro-Industrial Engineering program Study. He has finished the doctoral program in 25 months. He focuses on supply chain risk, optimization, big data, and implementation of IoT in supply chain and manufacture. At present, he works at Bhayangkara Jakarta Raya University as a lecturer and researcher since 2017. He is a practitioner in the industry before for 16+ years.

Rifki Muhendra, he works as a Lecturer and researcher at Industrial Engineering, Bhayangkara Jakarta Raya University, Indonesia. He received his bachelor's degree in Physics from Andalas University in 2010 and a master's degree in physics from Bandung Institute of Technology in 2013. He has more than ten years of experience in R&D and his research focuses on control systems, sensors, instrumentation systems, wireless sensor networks and the Internet of Things (IoT).

1 Introduction

Working quickly and safely has become a necessity for all companies. The application of high standards also continues to be applied to support company productivity. A lot of companies provide various types of material handling products, including overhead cranes and hoists, JIB cranes, Gantry cranes, and Hand trolley obstacles in the production process its workshop. The company often experiences a disruption such as process delays caused by the technical problem of the overhead crane and hoist operations they use. The author has made observations in the workshop to assemble this overhead crane girder and then got the delay frequency data on the process as seen in Figure 1 below.

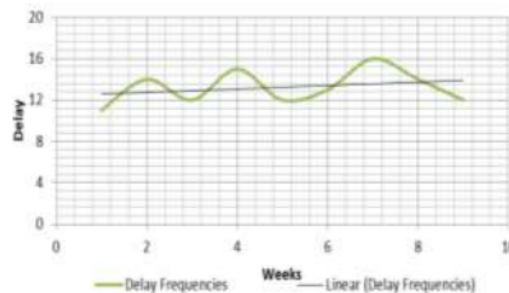

Figure1 Delay Frequencies (source: ARISTEC, 2020)

The industrial development into the digitalization era changes all instructions in analog and physical data and

received digital data. Data can be directly processed using computerized or digital data and provide an output that can be used as a basis for consideration in decision making. One of the outputs can be used to maintain the machines' consistency in the production process so that the machine continues to run. This study designs a safety device for cranes and hoists, one of the material handling tools used in industrial activity processes.

Recent developments regarding industrial digitization have also progressed towards the Internet of Things (IoT) (Fakhfakh, Kacem and Kacem, 2020). IoT allows all work devices are controlled using internet-based devices that will provide information accurately and quickly (Mahdi, Aljuboori and Hussein Ali, 2021). Research on the use of IoT also continues to grow, such as Stoyanova *et al.* (2020) who used the power of IoT for forensic purposes, where the development of this need is increasingly large and integrated and requires fast decision making. Another research was conducted by Khan *et al.* (2020), discussing IoT for an industry where IoT will increase efficiency in the production process and increase productivity. Utilization of IoT to predict preventive maintenance, quality control, and control of enterprise assets. For this reason, this study discusses the use of IoT in industry, where IoT technology is used to control the temperature on the motor hoist so that there is no delay due to overheating and will ultimately increase company productivity. The novelty of this research lies in the design model of the tool to control overheating using QFD and UML to get a product that suits the company's needs and is easy to apply. Then from the technology side of the hoist, it has not been obtained in previous studies controlling Hoist temperature using IoT.

2 Study Literature

2.1 Cranes and Hoist

In material handling or lifting and transportation tools, cranes and hoists are used to lift and move goods or machines that weigh with tonnage units, whether tens or even hundreds of tons. Those items or equipment can be lift only within the specified distance and coverage (Verma, 2019). The transfer of industrial goods and equipment that crane and hoist can do can be horizontal or vertical. Cranes and hoists are indispensable in the industrial world because they have essential functions: lifting and transport facilities in logistics, material handling for production processes, maintenance and installation of spare parts, installation of new industrial facilities, repairs, etc. Crane and hoist must always be maintained, checked, and evaluated for their performance because they are high risk tools. Thus, its function is crucial until the goods are lifted or transported by using it. Crane inspection must be carried out by experts who are professional in their fields because their duties are essential in providing a feasibility assessment assigned to them.

Steel girder or rod is a steel construction that has the most significant dimensions. This steel rod helps support all overhead cranes and hoists, electrical equipment, the movement of both trolley and hoist, and the movement of the girder itself. Besides, the overhead crane controller is also embedded in the girder (Shi *et al.*, 2019). Girder must withstand loads both from outside such as wind pressure, a moment of inertia, and loads from the overhead crane equipment itself. This force or load is transmitted to the foundation or other support installed in the building, where the overhead crane is mounted on the wheels at the end of carriage and runway rails. This steel rod must guarantee to maintain the strength and stability of the building. Therefore, the stresses on the separate elements must not exceed the safe threshold. Thus, the girder structure of the overhead crane should be sufficient (Maleki *et al.*, 2013).



Figure 2 Overhead crane hoist to lift the cut plate to the assembly line.

If the company wants to plan a girder crane, some conditions need to be considered, namely the material or plate to be used must have the correct specifications and thickness and the capacity of the overhead crane to be made (Pietrosanti, Holderbaum and Becerra, 2016). The calculation of the girder must be with a high degree of accuracy because several factors must be calculated, such as the strength of the material, moment, deflection, dimensions, etc. The girder to be made can guarantee or withstand loads and maintain the building's stability where the overhead crane is installed. The girder design must be calculated carefully, such as the shape of the goods to be lifted, the location of the overhead crane installation, the distance for moving goods, and the height of the goods to be moved to another place. Girder must also be able to provide work safety whether the overhead crane is used or not.

2.2 Process Design

To get a product that suits customer demand and field conditions, the design process is carried out using QFD for product design and UML for system design. The data is taken based on the conditions in the field, and an iteration is also carried out on the users and experts. Analytical Hierarchy Process (AHP) is a method for making decisions using pairwise comparisons between choice attributes and pairwise comparisons between options (Chen, 2015) (Munier, Hontoria and Jiménez-Sáez, 2019). In general, there are two considerations for decision making with AHP, namely criteria and choices. The function of AHP is to determine the degree of importance of each attribute that has been compared in pairs by an expert (Deepu and Ravi 2020 Nie *et al.* 2020).

Quality Function Deployment (QFD) is a method for designing a product or enhancing or modifying a product by adding value to the customer's wishes (Nie *et al.*, 2020). The customer's desires are poured into product design with technical specifications to meet the desires that customers are expecting (Ahmadzadeh *et al.*, 2020). QFD has a fundamental objective, i.e., finding out what customers want directly based on customer comments (Voice of Customer) to avoid mistakes in the marketing process and product design. This makes the product is being unable to compete in the market by customer expectations (Rianmora and Werawatganon, 2021). The product that is designed or proposed can then be used as a first step to improve various things, such as from the point of view of product quality, enhancing product features, and changing existing product designs to meet customer desires. In addition, QFD can reduce the time for the product development process, which is very complex. Some several phases or steps must be taken to make QFD, including interviews. In this study, the authors replaced it by directly brainstorming with the head of engineering of ARISTEC. This was to get a Voice of Customer who would translate what was needed by ARISTEC and know the level of customer interest in determining what was the priority in customer desires. Normality test of the data obtained through the results of a customer survey is to find out whether the data is normally distributed, then a validity test and building a House of Quality (HoQ) were conducted (Deepu and Ravi, 2020).

Unified Modeling Language (UML) is a standard language that is useful for writing or describing a blueprint or a detailed framework; it is also called an architecture for system development (Prakash and Prakash, 2018). The objectives of using UML is to provide a visual-based modeling communication tool, bring together the practices contained in modeling, and provide ready-to-use and expressive visual modeling to develop a system and product. However, it can also facilitate the exchange of models easily. It is used as a detailed framework or blueprint because UML can be said to be very detailed and complete for design. Modeling the system is not only for software-based but also object-oriented modeling, as well as creating a language that humans and machines can use. UML uses visual language to describe the designed system model. Visual type modeling has the advantage in which the readers understand the modeling faster than writing or programming languages (Thampi and El-Alfy, 2019). UML are divided into three major groups of diagrams, namely structure diagrams (system static structure), behavior diagrams (behavior or a series of changes to the system), and interaction diagrams (interactions between systems). This study uses all existing diagrams in UML only to show how the work or workflow of the security tools designed.

Therefore, this study merely uses case diagrams, activity diagrams, and sequence diagrams (Shtub and Karni, 2012). After carrying out the information system design, the next step is to implement it into the Arduino microcontroller device.

Arduino is an open source-based electronic platform based on the ease of using hardware and software (Barrett, 2013; (Barrett, 2010). From the hardware side, the Arduino board makes it easy for anyone to make prototypes of various electronics projects that ideally do not need soldering (Schubert, D'Ausilio and Canto, 2013). This board contains a microcontroller and various supporting devices such as memory and pins to handle the input and output (i/o) processes. Arduino UNO is a microcontroller board based on ATmega328. The Arduino UNO has 14 digital input/output pins (6 of which can be used as PWM outputs), a USB connection, six analog inputs, a 16 MHz Crystal oscillator, an ICSP header, a power jack, and a reset button. The Arduino UNO contains a tool that can support a microcontroller to easily connect it to a computer with a USB cable, connect an AC adapter to DC, or use a battery to start it up (Louis, 2016). The GSM module is part of the control center, which functions as a transceiver. The A6 GSM module is a miniature GSM modem that can integrate into many IoT projects (Eswar Kumar *et al.*, 2017; Ganesh, 2017; Gophal *et al.*, 2017; Mir *et al.*, 2019). This module can, among others, send text messages (SMS), make or receive phone calls, and connect to the internet via GPRS, TCP/IP (Giorgio and Melibeo, 2020). Additionally, this module supports quad-band GSM/GPRS networks (Ganesh, 2017) (Singh, Saini and Sood, 2020; Mahdi, Aljuboori and Hussein Ali, 2021). This module communicates with the microcontroller via UART and supports baud rates from 1200bps to 115200bps with Auto-Baud detection (Ma *et al.*, 2018). All the required data pins of the GSM A6 chip are split into a 0.1 pitch header. This module requires an external antenna for any voice or data communication and some SIM commands. It is usually equipped with a small duck antenna with a gain of 2 dBi and an impedance of 50Ω, which provides excellent coverage even if it is indoor.

This data can be used for further research using machine learning, such as the results of research conducted by (Goodarzian, Kumar and Abraham, 2021), or who developed Big Data for supply chain networks which also has a very significant impact on accelerating decision making in the production, distribution and transportation processes, ordering, and inventory control (Fakhfakh, Kacem and Kacem, 2020).

Table 1 shows the development and research carried out to improve the hoist system to know the novelty of this research and the location of this research towards existing research.

Table 1 Previous Study for Hoist Crane

Author	Research
(Shepherd, Kahler and Cross, 2000)	Analysis taxonomic for Crane fatalities
(Zaremba and Smoleński, 2000)	Input Shaping of the Hoist Drive of an Off-Shore Crane Using Nonlinear Optimisation Methods
(Parker <i>et al.</i> , 2003)	Make an experimental verification for command shaping boom in the crane control system.

(Pan, Liang and Liu, 2011)	Design of primary hoist mechanism for quay container crane
(Maleki <i>et al.</i> , 2013)	Design a dynamic response for dual-hoist bridge crane
(Pietrosanti, Holderbaum, and Becerra, 2016)	Design Power Flow Hoist Motor for Rubber-Tired Gantry Crane
(Gasiyarova <i>et al.</i> , 2017)	Modeling the Electric Drive of the Main Hoist of the Overhead Casting Crane with Two Driving Motors to avoid Usefulness of Using Elasticity of the Hoisting Tackle.
(Osmanaj <i>et al.</i> , 2018)	System sensitivity in speed control methods while induction motor Hoist for crane applications
(Verma, 2019)	RF Controller System for monitoring the PC Based Overhead Crane.
(Shi <i>et al.</i> , 2019)	Make a structural health monitoring system in the large-scale crane with IoT.
(Hara, 2018)	Integrating information data usage for quality function deployment (QFD) for improving PSS

Research to improve hoist and crane functions continues to be carried out by various researchers as shown in Table 1 above. It continues to develop in line with technological developments and is starting to take advantage of IoT technology. This study uses the Internet of Things as the basis for information systems. The novelty of this research is that the product is designed based on the initial needs in the field using AHP and QFD. After obtaining a product that is by the field requirements, the information system is designed using UML. The product design and design system

results are then implemented and tested with field conditions to determine whether the designed product meets the hoist crane control needs in the field and provides solutions to smooth the production process.

3 Methodology

The research method is a structured and systematic series used by researchers to solve problem phenomena that occur. Figure 2 shows a process flow or an overview of the framework used in this study.

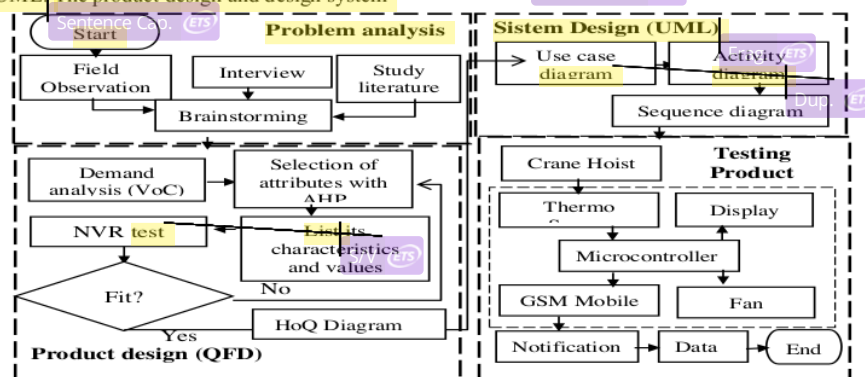

Figure 3 Research Methodology

Based on Figure 3 above, this research starts from field observations and literature studies. The two items were obtained for brainstorming with ARISTEC's head of engineering. After that, product planning is conducted using the QFD method after collecting the attributes resulted in interview and to be used in QFD. After getting the data from the interview, an analysis is conducted using AHP with the help of an expert to get the right attributes. After the product planning is carried out, product design is done using the UML method to describe the process flow of the hoist safety device, by convincing PT. ARISTEC that the tool will not interfere with the existing system workflow. After getting the data, brainstorming or discussion with the director of the Dept. ARISTEC's technique is done to analyze the causes of the problem and determine what is needed by ARISTEC to avoid the same problem in the future. The results of this

discussion include the expectations of ARISTEC and also the root or the cause of the problems that occurred in the ARISTEC workshop or the cause of the cessation of the operation of the Overhead Crane and Hoist at the ARISTEC workshop, i.e., the hoist is extremely hot. Delay in the process occurs when an overhead occurs, while the standard feature of making a hoist in the form of a thermal protector will automatically cut off electricity so that the hoist motor turns off. This tool will turn on the hoist automatically when the hoist motor temperature drops as set by the manufacturer. Based on the frequency of process delays, brainstorming results show there is an absence of tools to anticipate these problems. This research aims to provide a proposal for a hoist safety device that aims to detect, anticipate, and avoid the occurrence of overheating in the hoist to support the production process as soon as possible.

4 Result and Discussion

4.1 Decision priority with AHP

Once the interview was conducted, expert assistance was done to determine the appropriate attributes using the AHP

method. Figure 4 shows the AHP structure, while Figure 5 shows the result of the analysis using AHP.

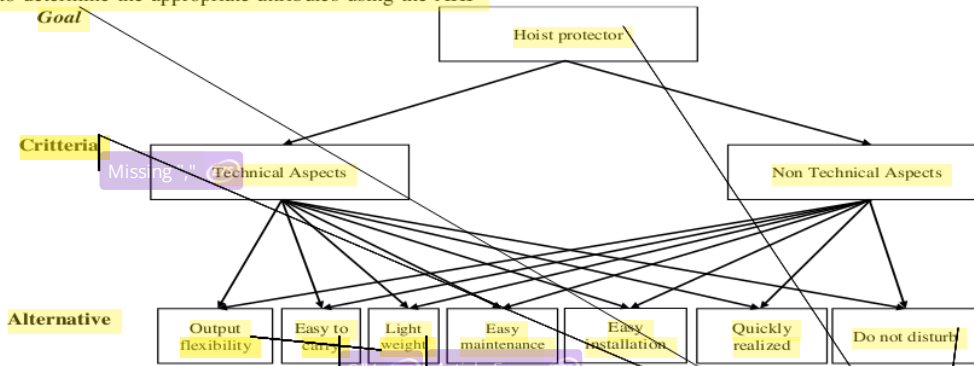

Figure 4 AHP structure for priority decision

Analysis using AHP begins by finding the Consistency index value; the chart in Figure 4 above shows that the experts' opinions for this study are consistent because the CI value is <0.1, as shown in Table 2

Table 2 Consistency Index

Cluster	CI	N	RI	CR = CI / RI
Design Hoist	0,00000	2	0,00	0
Technical Aspect	0,05168	7	1,32	0,03915

Table 3 shows that there are five attributes with the highest ranking. According to the expert, these attributes would be used as technical aspects related to the design of hoist safety

devices in this study. Here are five attributes: top-ranking Lightweight, easy maintenance, easy to carry, easy installation, and output flexibility.

Table 3 Results of analysis using AHP

Graphic	Alternatives	Total	Normal	Ideal	Ranking
■	Unobtrusive safety device	0.0222	0.0444	0.1372	7
■	Lightweight	0.0791	0.1582	0.4884	3
■	Quickly realized	0.0282	0.0564	0.1742	6
■	Output flexibility	0.1620	0.3240	1.0000	1
■	Easy to carry	0.0402	0.0804	0.2480	5
■	Easy installation	0.1202	0.2404	0.7419	2
■	Easy maintenance	0.0481	0.0962	0.2969	4

The criteria selected above serve as the basis for the proposed hoist safety device in maximizing the hoist's performance for the overhead crane girder production process.

After the analysis of AHP, 5 of the seven attributes were selected to be used as attributes in QFD. Each of these attributes has a weighted value, and this value weight determines the Importance Rating Value, which is helpful in knowing which attributes are most important to customers. The following is a list of attributes, weight values, and importance rating.

4.2 Design Model with QFD

Table 4 List of attributes and their weighted values

Attribute	Number of Votes				
	STD	TD	D	LD	SD
Lightweight		3	2	1	4
Easy maintenance			3	4	3
Easy to carry	1	1	4	2	2
Easy installation			3	3	4

Quickly realized

The determination of the level of importance is obtained from the wishes of the company management by the needs of the consumers obtained from brainstorming with the company management. The determination of the level of importance was carried out to determine the importance of each of the respondent's criteria. The following is the formula for calculating the importance rating:

$$IR = \frac{\text{the number of respondents voted} \times \text{Interest Weight}}{\text{Number of Questionnaire}} \quad (1)$$

The following is an example of the calculation for the first attribute, namely light weight and portability:

1. STD : 1 x 0 = 0
2. TD : 2 x 3 = 6
3. D : 3 x 2 = 6
4. LD : 4 x 1 = 4
5. SD : 5 x 4 = 20

$$IR \text{ of Quickly Realized} = \frac{(0 + 6 + 6 + 4 + 20)}{10} = 3,6$$

The level of importance rating for each attribute was calculated, and the results are summarized in the following graph:

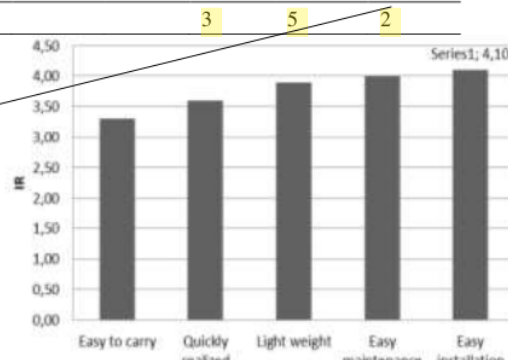

Figure 5 The graph of the Importance Rating for criteria design product.

Figure 5 above shows that the easy installation attribute has the highest importance rating. This attribute is an attribute that customers expect to fulfill or realize first—after determining the importance rating, determining the technical needs, and determining the relationship. Below are the tables and matrices that describe its relationship.

Table 5 List of technical requirements by customer needs

Customer Needs	Technical Requirements
Lightweight	Weight of constituent components
Easy maintenance	Product installation location
Easy to carry	Design tools
Easy installation	Case design
Quickly realized	Components are easy to get

Table 6 Relationship between consumer needs and technical needs

customer needs	IR	Technical Requirements				
		1	2	3	4	5
Lightweight	3,6	△		●	○	○
Easy maintenance	4		△	●	○	
Easy to carry	3,3	△		○	△	●
Easy installation	4,1		△		○	
Output flexibility	4,3	●			○	△

Table 6 shows the relationship between consumer needs and technical needs. There are three levels of relationship, namely strong, medium, and weak. The stronger the technical relationship, the more influential the technical relationship in meeting customer needs. A triangle symbol means a strong relationship, a circle symbol means a moderate relationship, and a colored circle symbol means a weak relationship. There are six strong relationships, six medium relationships, and two weak relationships. After getting the value of the relationship, the absolute importance value can be determined. Here is a graph for absolute importance values.

This value of importance is related to predetermined technical needs, determining which activities or technical specifications must be carried out or fulfilled first. In the process of making the tools, it needs structured planning. The following is the formula used to determine the value of absolute importance:

$$Kt = \sum(Bti \times Hi) \quad (2)$$

Where:

Kt : Absolute importance value.

Bti : The weight of the relative importance of consumer desires that has a relationship with the attribute.

H_i : The value of the relationship between consumer desires and attributes

The following is an example of calculating the attribute "Weight of constituent components" with absolute importance level.

$$Kt = \sum(B_{ti} \times H_i) \quad (3)$$

$$Kt = \sum(3,6 \times 9) + (4 \times 0) + (3,3 \times 9) + (4,1 \times 0) + (4,3 \times 1) = 66,4$$

The calculation of the absolute importance value was carried out for all the attributes of technical requirements. The calculation results for all the attributes of technical requirements can be seen in the following table.

Table 7 Absolute importance value

No	Technical Requirements	Absolute Importance Value
1	Component Weight	66,4
2	Product Installation Location	72,9
3	Design Tools	17,5
4	Casing Design	77,7
5	Using wireless	52,8

Figure 6 shows that three technical requirements must be prioritized and paid attention to when developing the tool. The final step is to create a House of Quality matrix with the above processing as the basis. The following is the House of Quality matrix in planning hoist safety devices.

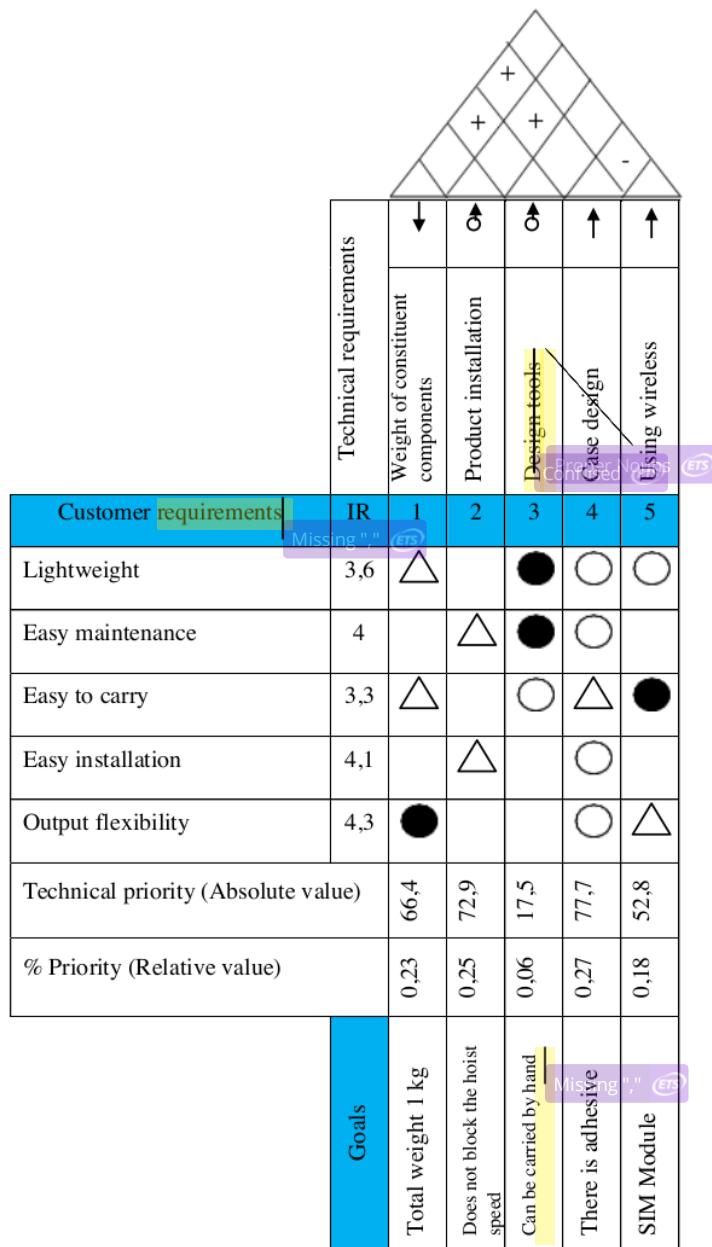

Figure 6 House of Quality hoist safety device

4.3 Design Information System using UML

After getting design proposals and product specifications with QFD, product design was done using UML to describe the process flow of the hoist safety device, and to convince ARISTEC that the tool would not interfere with the existing workflow of the system.

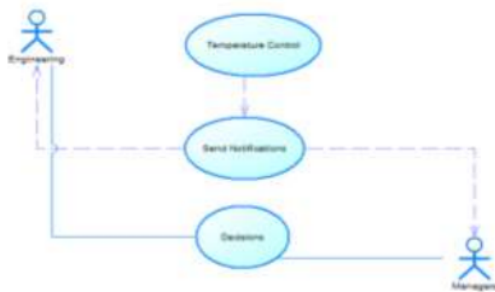

Figure 7 Use Case diagram for information hoist temperature

Figure 7 uses a case diagram to determine the actors involved in the system. There are two actors in the hoist safety system, namely the managers and engineering.

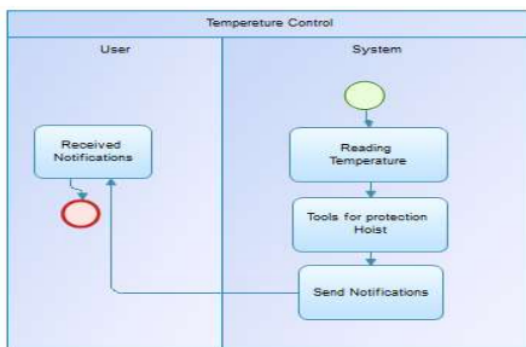

Figure 8 Activity diagram for notification temperature control

Activity diagrams in Figure 8 help provide an overview of the hoist safety device workflow. This hoist safety system will detect the hoist temperature as an input; then, if the input exceeds the manufacturer's limit, the system will send a notification to the operator or the last user. The user or operator will get the information.

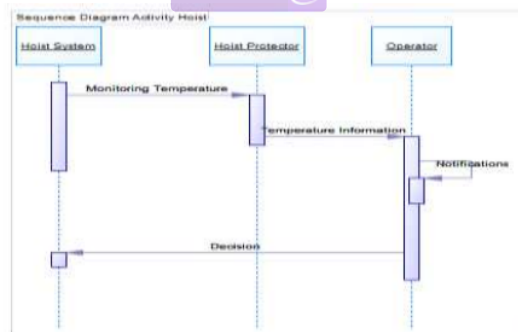

Figure 9 Sequence diagram for Hoist Protector

Sequence diagram in Figure 9 is useful for providing an overview of the interaction of objects with other objects

both within the system and outside the system. Besides, this diagram is also used to show messages sent and received by objects. Figure 8 shows that the existing system, namely the hoist system, is not disturbed by the new system or the proposed system in the form of a hoist safety device.

4.4 Product Testing

Product manufacturing followed the product design made using QFD in section 4.2 above and the design of the information system in 4.3. The product must have a flexible output; easy to install and maintain, light energy, and easy to carry. The ease of information is obtained by all actors who control the machine so that decision-making can be easily carried out and losses due to product and machine damage can also be avoided.

This research focuses on measuring the temperature of the hoist motor to prevent overheating, which can cause the motor in the hoist to stop working. The design can be seen in the following figure.

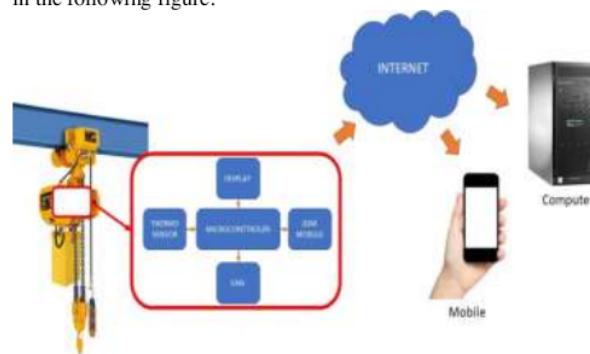

Figure 10 Design of Overheat Control for Crane Hoist Based on Internet of Thing

Figure 10 is an Overheat Control for Crane Hoist Based on the designed Internet of Thing. This system consists of Overheat Control hardware and an IoT-based information system. The hardware consists of a heat sensor that measures the temperature on the hoist, a microcontroller, a display in the form of an LCD and a fan as a hoist temperature controller, and a GSM module as a data bridge to the internet. The sensor used is a thermocouple that can measure the temperature of the metal layer up to 700°C. The data from the measurement results will be processed by the microcontroller to be displayed on the LCD and then proceed to send data to the internet using the GSM communication protocol. For the fan itself, it will automatically work if it receives a switch signal from the microcontroller. When the rated hoist temperature approaches the overheat temperature, the microcontroller will send signal to the fan. However, when the temperature is close to normal temperature, the microcontroller will send an off signal to the fan.

A web server is used to accommodate real-time hoist data on the internet. The web server used is Thingspeak. It is a firebase that is popularly used for IoT-based monitoring and control projects. It has features for data processing. Hoist temperature measurement data can be displayed in graphs or numeric. If a control failure condition occurs,

Thingspeak can also give a warning output to the user. Hoist temperature data updates are carried out every 15 seconds. To access this Thingspeak, the company can use an internet computer or a mobile device such as Android.

```

Thermocouple Library
SIM 8001 Library
LCD i2C Library

Var data;

Begin (){
Init thermocouple;
Init LCD;
Init SIM 8001;

Data = temperature value ();

If data > hot value, then turn on the fan
Else turn off the fan

Send data to Cloud with GSM;
Delay (15)
}
    
```

Figure 11 Algorithm of the device

Figure 11 shows the structure of the Overheat Control algorithm. This algorithm is built using libraries that have been developed previously by several Arduino communities, namely the thermocouple library, the I2C LCD library, and the GSM SIM 8001 library. The critical point of this algorithm is to measure the heat capacity that occurs in the hoist machine. The read value will be displayed on the LCD and sent to the internet via the GSM protocol. If this value exceeds the heat capacity that the engine can accept, the Arduino will generate a signal to turn on the fan. Otherwise, the signal will be turned off. This algorithm will be repeated to get the heat value in real-time. The overheat control device that has been built can be seen in Figure 10.

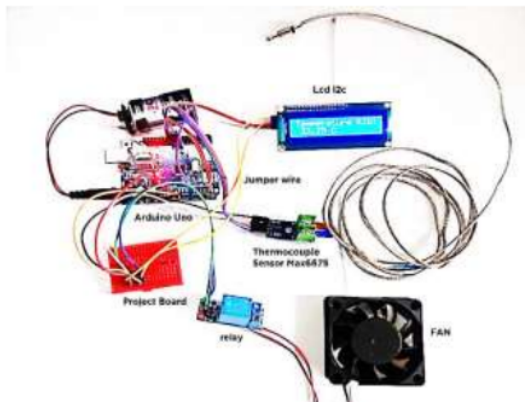
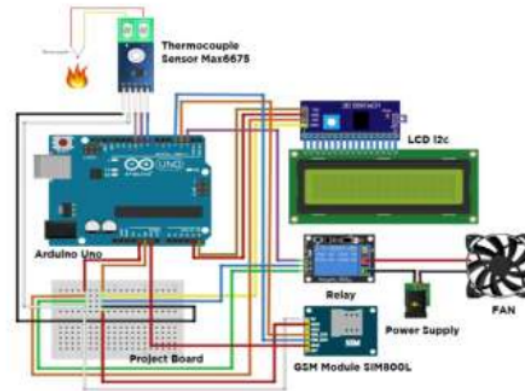

Figure 12 Design and actual physical form of the overheat control device circuit.

This overheats protection device will issue data as an evaluation materials for the industry, considering that the increase in motor temperature is also influenced by the viscosity of the stirred product and the volume of the tank. With notes and notifications, this condition will help engineering control the quality of products based on tank volume and motor power.

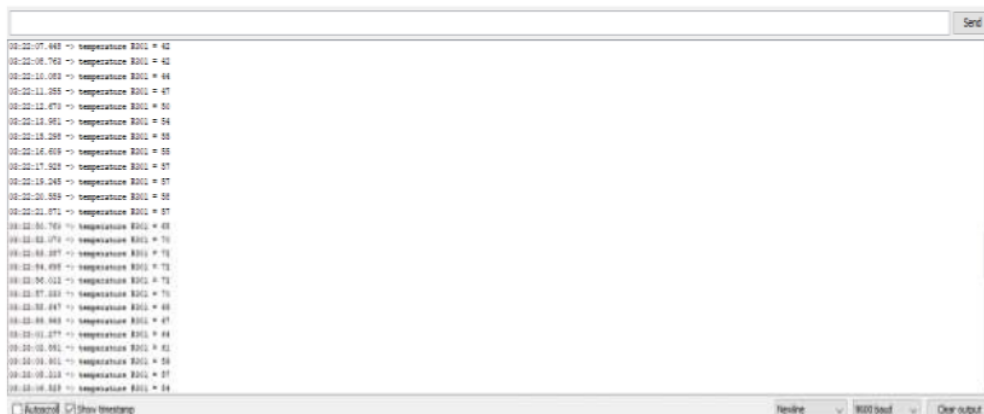

Figure 13 Read the value on the serial machine temperature Monitor

Different values can be seen in the reading results on the Arduino IDE application. At this stage, the thermocouple sensor max 6657 reads the overheat temperature > 60°C. Then Arduino will command the relay, and the relay will work with the cooling fan to cool the Hoist Motor. If the Hoist Motor temperature is < 60°C, the cooling fan will turn off.

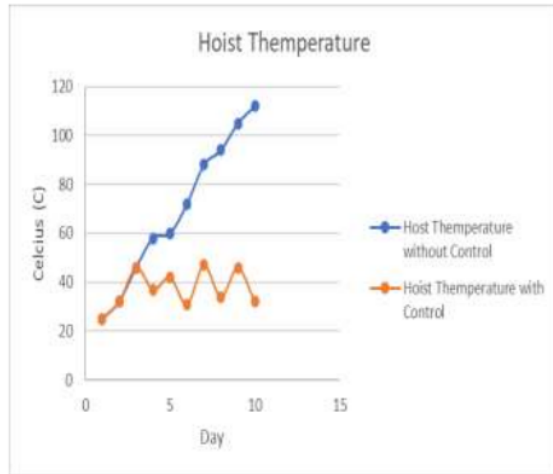

Figure 14 Graph of temperature before and after implementation of the device

The results of field experiments regarding applying an overheat protection device for this hoist effectively prevent machine damage due to known actions. With the information system directly connected to the engineering team, abnormal events can be quickly handled. From Figure 14, we can see that this tool is very effective in controlling the motor's temperature and can increase the productivity of the machine and the engineering.

5 Conclusion

This research has succeeded in designing products and information systems according to company needs. Product design using QFD and information system design using UML in this study resulted in a product that is easy to use, easy to carry, lightweight, and can provide notifications in an emergency via GSM devices. This research has produced a novelty for a temperature control system to prevent overheating using the Internet of Thing based Arduino Uno and Thingspeak. The Arduino Uno device with a microcontroller can also control the temperature rise of the product to avoid overheating. The tools designed with two actions, namely turning on the fan to cool the engine and notifying the engineer, will make it easier to make decisions. Further research is recommended to utilize the data obtained from temperature control using artificial intelligence and machine learning so that the control can be carried out by itself, and the decisions taken can be given using machine learning.

6 References

- Ahmadzadeh, A. *et al.* (2020) 'Developing a QFD model for prioritizing the CSFs of ERP based on the enablers of organizational agility', *Benchmarking*, (2008). doi: 10.1108/BIJ-08-2020-0411.
- Barrett, S. F. (2010) *Arduino Microcontroller: Processing for Everyone! Part II, Synthesis Lectures on Digital Circuits and Systems*. doi: 10.2200/s00283ed1v01y201005dcs029.
- Barrett, S. F. (2013) *Arduino Microcontroller Processing for Everyone!* 3rd edn. Edited by S. M. U. Mitchell A.Thornton and The. Laramie,WY: Morgan & Claypool Publisher.
- Chen, R. Y. (2015) 'Intelligent IoT-Enabled System in Green Supply Chain using Integrated FCM Method', *International Journal of Business Analytics*, 2(3), pp. 47–66. doi: 10.4018/IJBAN.2015070104.
- Deepu, T. S. and Ravi, V. (2020) 'An integrated ANP–QFD approach for prioritization of customer and design requirements for digitalization in an electronic supply chain', *Benchmarking*. doi: 10.1108/BIJ-06-2020-0298.
- Eswar Kumar, M. *et al.* (2017) 'Vehicle Theft Identification and Intimation Using GSM & IOT', *IOP Conference Series: Materials Science and Engineering*, 263(4). doi: 10.1088/1757-899X/263/4/042062.
- Fakhfakh, F., Kacem, H. H. and Kacem, A. H. (2020) 'Ensuring the correctness of adaptive business processes: A systematic literature review', *International Journal of Computer Applications in Technology*, 62(3), pp. 189–199. doi: 10.1504/IJCAT.2020.106568.
- Ganesh, E. N. (2017) 'Implementation of IOT Architecture for SMART HOME using GSM Technology', *International Journal of Computer Techniques*, 4(1), pp. 42–48. Available at: <http://www.ijctjournal.org>.
- Gasiyarova, O. A. *et al.* (2017) 'Usefulness of Using Elasticity of the Hoisting Tackle in Modeling the Electric Drive of the Main Hoist of the Overhead Casting Crane with Two Driving Motors', *Procedia Engineering*. Elsevier B.V., 206, pp. 1861–1866. doi: 10.1016/j.proeng.2017.10.726.
- Giorgio, A. and Melibeo, A. (2020) 'Data acquisition and stream processing with Matlab using system objects', *International Journal of Computer Applications in Technology*, 62(3), pp. 246–256. doi: 10.1504/IJCAT.2020.106589.
- Goodarziyan, F., Kumar, V. and Abraham, A. (2021) *Hybrid meta-heuristic algorithms for a supply chain network considering different carbon emission regulations using big data characteristics*, *Soft Computing*. Springer Berlin Heidelberg. doi: 10.1007/s00500-021-05711-7.
- Gophal, C. S. S. K. *et al.* (2017) 'UPS Parameter Monitoring and Controlling Using IOT and GSM', *International Journal of Pure and Applied Mathematics*, 116(6), pp. 133–139.
- Hara, T. (2018) 'Integrating usage information into quality function deployment for further PSS development', *Procedia CIRP*. Elsevier B.V., 73, pp. 21–25. doi: 10.1016/j.procir.2018.03.323.
- Khan, W. Z. *et al.* (2020) 'Industrial internet of things: Recent advances, enabling technologies and open challenges', *Computers and Electrical Engineering*. Elsevier Ltd, 81, p. 106522. doi:

10.1016/j.compeleceng.2019.106522.

Louis, L. (2016) 'Working Principle of Arduino and Using it as a Tool for Study and Research', *International Journal of Control, Automation, Communication and Systems*, 1(2), pp. 21–29. doi: 10.5121/ijcaacs.2016.1203.

Ma, Y. *et al.* (2018) 'Development and application of an atmospheric pollutant monitoring system based on LoRa—part I: Design and reliability tests', *Sensors (Switzerland)*, 18(11). doi: 10.3390/s18113891.

Mahdi, M. J., Aljuboori, A. F. and Hussein Ali, M. (2021) 'Smart Stadium using Cloud Computing and Internet of Things (IoT): Existing and New Models', *International Journal of Computer Applications Technology and Research*, 10(05), pp. 111–118. doi: 10.7753/ijcatr1005.1002.

Maleki, E. *et al.* (2013) 'Dynamic response of a dual-hoist bridge crane', *ASME 2013 Dynamic Systems and Control Conference, DSCC 2013*, 3(1), pp. 1–8. doi: 10.1115/DSCC2013-3955.

Mir, S. H. *et al.* (2019) 'Review on Smart Electric Metering System Based on GSM / IOT', 8(1), pp. 1–6.

Munier, N., Hontoria, E. and Jiménez-Sáez, F. (2019) *Strategic Approach in Multi-Criteria Decision Making*. doi: 10.1007/978-3-030-02726-1.

Nie, R. xin *et al.* (2020) 'Implementing healthcare service quality enhancement using a cloud-support QFD model integrated with TODIM method and linguistic distribution assessments', *Journal of the Operational Research Society*. Taylor & Francis, 0(0), pp. 1–23. doi: 10.1080/01605682.2020.1824554.

Osmanaj, S. *et al.* (2018) 'The sensitivity of the hoist system in crane applications from speed control methods at induction motor', *Elektrotechnik und Informationstechnik*. Springer-Verlag GmbH Austria, ein Teil von Springer Nature, 135(2), pp. 195–203. doi: 10.1007/s00502-018-0606-7.

Pan, Y., Liang, C. and Liu, L. (2011) 'The modeling of main hoist mechanism of quay container crane', *Proceedings - 2011 4th International Conference on Information Management, Innovation Management and Industrial Engineering, ICIII 2011*, 3(November 2011), pp. 377–381. doi: 10.1109/ICIII.2011.373.

Parker, G. G. *et al.* (2003) 'Experimental verification of a command shaping boom crane control system', (June), pp. 86–90 vol.1. doi: 10.1109/acc.1999.782745.

Pietrosanti, S., Holderbaum, W. and Becerra, V. M. (2016) 'Modeling Power Flow in a Hoist Motor of a Rubber-Tired Gantry Crane', *IEEE Transactions on Industry Applications*, 52(3), pp. 2088–2094. doi: 10.1109/TIA.2016.2529560.

Prakash, N. and Prakash, D. (2018) *Data Warehouse Requirements Engineering*.

Rianmora, S. and Werawatganon, S. (2021) 'Applying quality function deployment in open innovation engineering', *Journal of Open Innovation: Technology, Market, and Complexity*, 7(1), pp. 1–20. doi: 10.3390/joitmc7010026.

Schubert, T. W., D'Ausilio, A. and Canto, R. (2013) 'Using Arduino microcontroller boards to measure response latencies', *Behavior Research Methods*, 45(4), pp. 1332–1346. doi: 10.3758/s13428-013-0336-z.

Shepherd, G. W., Kahler, R. J. and Cross, J. (2000) 'Crane fatalities - A taxonomic analysis', *Safety Science*, 36(2), pp. 83–93. doi: 10.1016/S0925-7535(00)00017-5.

Shi, Y. *et al.* (2019) 'Designing a structural health monitoring system for the large-scale crane with narrow band IoT', *Proceedings of the 2019 IEEE 23rd International Conference on Computer Supported Cooperative Work in Design, CSCWD 2019*, pp. 239–242. doi: 10.1109/CSCWD.2019.8791899.

Shtub, A. and Karni, R. (2012) *ERP, Springer*.

Singh, M. K., Saini, I. and Sood, N. (2020) 'A multi-functional BCI system for exigency assistance and environment control based on ML and IoT', *International Journal of Computer Applications in Technology*, 63(1–2), pp. 64–82. doi: 10.1504/IJCAT.2020.107912.

Stoyanova, M. *et al.* (2020) 'A Survey on the Internet of Things (IoT) Forensics: Challenges, Approaches, and Open Issues', *IEEE Communications Surveys and Tutorials*. IEEE, 22(2), pp. 1191–1221. doi: 10.1109/COMST.2019.2962586.

Thampi, S. M. and El-Alfy, E. S. M. (2019) 'Soft computing and intelligent systems: Techniques and applications', *Journal of Intelligent and Fuzzy Systems*, 36(3), pp. 1939–1944. doi: 10.3233/JIFS-169905.

Verma, K. (2019) 'A Technique for Monitoring the PC Based Overhead Crane with RF Controller System', pp. 77–83.

Zaremba, L. S. and Smoleński, W. H. (2000) 'Application of Nonlinear Optimisation Methods to Input Shaping of the Hoist Drive of an Off-Shore Crane', *Annals of Operations Research*, 97(1–4), pp. 131–141. doi: 10.1023/A.

Overheat Protection for Motor Crane Hoist Using Internet of Thing

ORIGINALITY REPORT

2%

SIMILARITY INDEX

1%

INTERNET SOURCES

1%

PUBLICATIONS

2%

STUDENT PAPERS

PRIMARY SOURCES

1

Submitted to Kazakh-British Technical
University

Student Paper

1%

2

www.ijcrbp.com

Internet Source

1%

Exclude quotes On

Exclude matches < 1%

Exclude bibliography On

Overheat Protection for Motor Crane Hoist Using Internet of Thing

PAGE 1



Sp. This word is misspelled. Use a dictionary or spellchecker when you proofread your work.



Article Error You may need to use an article before this word.



Article Error You may need to use an article before this word.



Article Error You may need to use an article before this word. Consider using the article **the**.



Prep. You may be using the wrong preposition.

PAGE 2



Wrong Form You may have used the wrong form of this word.



Article Error You may need to use an article before this word. Consider using the article **the**.



P/V You have used the passive voice in this sentence. You may want to revise it using the active voice.



Prep. You may be using the wrong preposition.



Article Error You may need to use an article before this word.



Missing "," Review the rules for using punctuation marks.



Article Error You may need to remove this article.



Prep. You may be using the wrong preposition.



Article Error You may need to use an article before this word. Consider using the article **the**.



Sp. This word is misspelled. Use a dictionary or spellchecker when you proofread your work.



Sp. This word is misspelled. Use a dictionary or spellchecker when you proofread your work.



P/V You have used the passive voice in this sentence. You may want to revise it using the active voice.



P/V You have used the passive voice in this sentence. You may want to revise it using the active voice.



Sp. This word is misspelled. Use a dictionary or spellchecker when you proofread your work.



Sp. This word is misspelled. Use a dictionary or spellchecker when you proofread your work.



Sp. This word is misspelled. Use a dictionary or spellchecker when you proofread your work.



Wrong Form You may have used the wrong form of this word.



Proper Nouns You may need to use a capital letter for this proper noun.



Sp. This word is misspelled. Use a dictionary or spellchecker when you proofread your work.



P/V You have used the passive voice in this sentence. You may want to revise it using the active voice.



Article Error You may need to use an article before this word.



Article Error You may need to use an article before this word. Consider using the article **the**.



Sp. This word is misspelled. Use a dictionary or spellchecker when you proofread your work.



Proper Nouns You may need to use a capital letter for this proper noun.



Sp. This word is misspelled. Use a dictionary or spellchecker when you proofread your work.



Prep. You may be using the wrong preposition.



Article Error You may need to use an article before this word. Consider using the article **a**.



Prep. You may be using the wrong preposition.



Article Error You may need to use an article before this word.



Article Error You may need to remove this article.



Article Error You may need to use an article before this word.



Article Error You may need to use an article before this word. Consider using the article **the**.



Article Error You may need to use an article before this word. Consider using the article **the**.



Frag. This sentence may be a fragment or may have incorrect punctuation. Proofread the sentence to be sure that it has correct punctuation and that it has an independent clause with a complete subject and predicate.



Frag. This sentence may be a fragment or may have incorrect punctuation. Proofread the sentence to be sure that it has correct punctuation and that it has an independent clause with a complete subject and predicate.



Article Error You may need to remove this article.



Frag. This sentence may be a fragment or may have incorrect punctuation. Proofread the sentence to be sure that it has correct punctuation and that it has an independent clause with a complete subject and predicate.



Frag. This sentence may be a fragment or may have incorrect punctuation. Proofread the sentence to be sure that it has correct punctuation and that it has an independent clause with a complete subject and predicate.



Frag. This sentence may be a fragment or may have incorrect punctuation. Proofread the sentence to be sure that it has correct punctuation and that it has an independent clause with a complete subject and predicate.



Missing ", " Review the rules for using punctuation marks.



P/V You have used the passive voice in this sentence. You may want to revise it using the active voice.



Sentence Cap. Review the rules for capitalization.



Article Error You may need to use an article before this word.



S/V This subject and verb may not agree. Proofread the sentence to make sure the subject agrees with the verb.



Word Error Did you type **the** instead of **they**, or have you left out a word?



P/V You have used the passive voice in this sentence. You may want to revise it using the active voice.



Article Error You may need to use an article before this word.



Sentence Cap. Review the rules for capitalization.



Frag. This sentence may be a fragment or may have incorrect punctuation. Proofread the sentence to be sure that it has correct punctuation and that it has an independent clause with a complete subject and predicate.



Dup. Did you mean to repeat this word?



S/V This subject and verb may not agree. Proofread the sentence to make sure the subject agrees with the verb.



Article Error You may need to use an article before this word.



Proofread This part of the sentence contains an error or misspelling that makes your meaning unclear.











Article Error You may need to remove this article.











P/V You have used the passive voice in this sentence. You may want to revise it using the active voice.



P/V You have used the passive voice in this sentence. You may want to revise it using the active voice.

-  **Missing ",,"** Review the rules for using punctuation marks.
-  **Article Error** You may need to use an article before this word.
-  **S/V** This subject and verb may not agree. Proofread the sentence to make sure the subject agrees with the verb.
-  **Article Error** You may need to use an article before this word. Consider using the article **the**.
-  **Sp.** This word is misspelled. Use a dictionary or spellchecker when you proofread your work.
-  **P/V** You have used the passive voice in this sentence. You may want to revise it using the active voice.
-  **Prep.** You may be using the wrong preposition.
-  **Article Error** You may need to use an article before this word.

-  **P/V** You have used the passive voice in this sentence. You may want to revise it using the active voice.
-  **Proper Nouns** You may need to use a capital letter for this proper noun.
-  **Proper Nouns** You may need to use a capital letter for this proper noun.
-  **Prep.** You may be using the wrong preposition.
-  **Article Error** You may need to use an article before this word.
-  **Article Error** You may need to remove this article.
-  **Article Error** You may need to use an article before this word.
-  **Prep.** You may be using the wrong preposition.
-  **Article Error** You may need to use an article before this word.



Article Error You may need to use an article before this word.



Article Error You may need to remove this article.



Prep. You may be using the wrong preposition.

PAGE 7



Frag. This sentence may be a fragment or may have incorrect punctuation. Proofread the sentence to be sure that it has correct punctuation and that it has an independent clause with a complete subject and predicate.



Article Error You may need to use an article before this word.



Prep. You may be using the wrong preposition.

PAGE 8



Proper Nouns You may need to use a capital letter for this proper noun.



Confused You have used either an imprecise word or an incorrect word.



Missing "," Review the rules for using punctuation marks.



Missing "," Review the rules for using punctuation marks.



Missing "," Review the rules for using punctuation marks.

PAGE 9



P/V You have used the passive voice in this sentence. You may want to revise it using the active voice.



P/V You have used the passive voice in this sentence. You may want to revise it using the active voice.



Sp. This word is misspelled. Use a dictionary or spellchecker when you proofread your work.



P/V You have used the passive voice in this sentence. You may want to revise it using the active voice.



Article Error You may need to use an article before this word. Consider using the article **the**.



Article Error You may need to remove this article.



Sp. This word is misspelled. Use a dictionary or spellchecker when you proofread your work.



Article Error You may need to remove this article.



Article Error You may need to remove this article.



Sp. This word is misspelled. Use a dictionary or spellchecker when you proofread your work.



Sp. This word is misspelled. Use a dictionary or spellchecker when you proofread your work.



Word Error Did you type **the** instead of **they**, or have you left out a word?



Sp. This word is misspelled. Use a dictionary or spellchecker when you proofread your work.



Article Error You may need to use an article before this word.



Sp. This word is misspelled. Use a dictionary or spellchecker when you proofread your work.



S/V This subject and verb may not agree. Proofread the sentence to make sure the subject agrees with the verb.



P/V You have used the passive voice in this sentence. You may want to revise it using the active voice.



Word Error Did you type **the** instead of **they**, or have you left out a word?



Possessive Review the rules for possessive nouns.



Article Error You may need to use an article before this word.



P/V You have used the passive voice in this sentence. You may want to revise it using the active voice.



Word Error Did you type **the** instead of **they**, or have you left out a word?



Prep. You may be using the wrong preposition.

PAGE 11



Word Error Did you type **the** instead of **they**, or have you left out a word?



Proofread This part of the sentence contains an error or misspelling that makes your meaning unclear.



Article Error You may need to remove this article.



Sp. This word is misspelled. Use a dictionary or spellchecker when you proofread your work.



Article Error You may need to remove this article.



P/V You have used the passive voice in this sentence. You may want to revise it using the active voice.

PAGE 12
