

PAPER • OPEN ACCESS

## Designing of temperature control for agitator machine using Internet of Thing

To cite this article: P Paduloh *et al* 2022 *IOP Conf. Ser.: Earth Environ. Sci.* **1063** 012053

View the [article online](#) for updates and enhancements.

You may also like

- [Numerical simulation of acoustic field under mechanical stirring](#)  
Jin-He Liu, , Zhuang-Zhi Shen et al.
- [Design and performance test of biodiesel reactor using hellical screw agitator and baffles](#)  
D Wulandani and Z A Ibrahim
- [Study on the aggregate motion for gas-liquid-solid agitated tank reactors design using radioactive particle tracking](#)  
Gabriel Salierno, Mauricio Maestri, María Sol Fraguío et al.



**245th ECS Meeting**  
**San Francisco, CA**  
May 26–30, 2024

**PRiME 2024**  
**Honolulu, Hawaii**  
October 6–11, 2024

Bringing together industry, researchers, and government across 50 symposia in electrochemistry and solid state science and technology

Learn more about ECS Meetings at  
<http://www.electrochem.org/upcoming-meetings>

 Save the Dates for future ECS Meetings!

# Designing of temperature control for agitator machine using Internet of Thing

**P Paduloh<sup>\*</sup>, H Fatahillah, M A Ramadhan, R Muhendra, M Widyantoro and Sumanto**

Industrial Engineering Program Study, Bhayangkara Jakarta Raya University, Bekasi, Indonesia

E-mail: [paduloh@dsn.ubharajaya.ac.id](mailto:paduloh@dsn.ubharajaya.ac.id)

**Abstract.** Aristek Highpolymer is a company that produces emulsion polymers and synthetic resins. In the production process, the R301 agitator has often experienced overheating, which disrupted the production process and caused damage to the mixer engine motor. Currently, checking the temperature on the Agitator R301 has been done manually using a thermo-gun and often caused the information to be hampered and several times caused the stirrer motor to go off. For this reason, this study designed a tool that could facilitate checking and reporting if there was an increase in engine temperature. This tool utilized an information system using the concept of Web-Based Internet of Things (IoT). The information system was designed using UML, and the temperature reader was designed using Arduino Uno, Max6675 temperature sensor, and GSM SIM 800L module using the Fritzing application. Product design was done using QFD to get the design of the control device according to the customer's wishes. The research and experiments obtained a machine temperature controller that could provide information directly to decision-makers if an abnormal event occurred in the machine. It could also control the engine temperature so that it increased productivity and decreased maintenance costs for the agitator machine.

## 1. Introduction

Aristek Highpolymer is a company that produces emulsion polymers and synthetic resins for vehicle paints and car care. In the production process at Aristek Highpolymer, several times, there were disturbances in the form of overheating with temperature conditions exceeding 60°C on the R301 mixer machine. The impact of overheating can cause the production process to stop for 2 to 4 hours, and the worst thing can cause the agitator (mixing machine) to be damaged and must be replaced due to fire. The author observed the engine and then obtained overheating data on the R301 engine in the last five months. The author summarizes the findings in Figure 1 below.

From the data in Figure 1, it can be seen that the agitator temperature often exceeds the safety standard of 60 degrees Celsius. When the engine conditions reach that temperature, the engine must be turned off because it will cause it to go off and burn if forced to work. However, currently, in the production area, temperature checking is still done manually. They often miss the temperature conditions in the production area, so the engine motor is damaged and must be replaced several times.

---

<sup>\*</sup> To whom any correspondence should be addressed.



In terms of safety, this condition is also hazardous because the product produced is a flammable chemical, so if a spark occurs, it can cause a bigger fire.

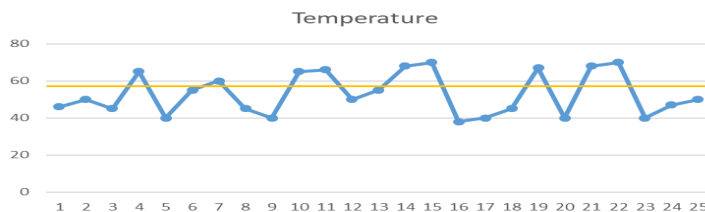

**Figure 1.** Data temperature in Agitator machine by observations.

Previous research on IoT implementation has been widely carried out, such as [1] making IoT applications for forensic activities, [2] Detecting Botnet Attacks in IoT Environment, [3] Smart Stadium using Cloud Computing and Internet of Things (IoT): Existing and New Models, [4] Intelligent service-integrated platform based on IOT technology using FCM and FQFD method, [5] Implementation of IoT Architecture for SMART HOME using GSM Technology but IoT research for implementation on agitator motors has not been done before. This research will be beneficial to increase the productivity of the company's production and prevent engine damage due to rising temperatures.

Based on these conditions, this research tries to design a tool that makes it easier for operators, staff, and decision-makers to receive temperature information efficiently to make decisions quickly. The state of the art research lies in product design, information system design, then implementing the product and conducting testing to determine the performance of the resulting product.

## 2. Methodology

The research method, which is an automatic system, is used to solve the problems. The following (Figure 2) is a process flow or an overview of the framework used in this research.

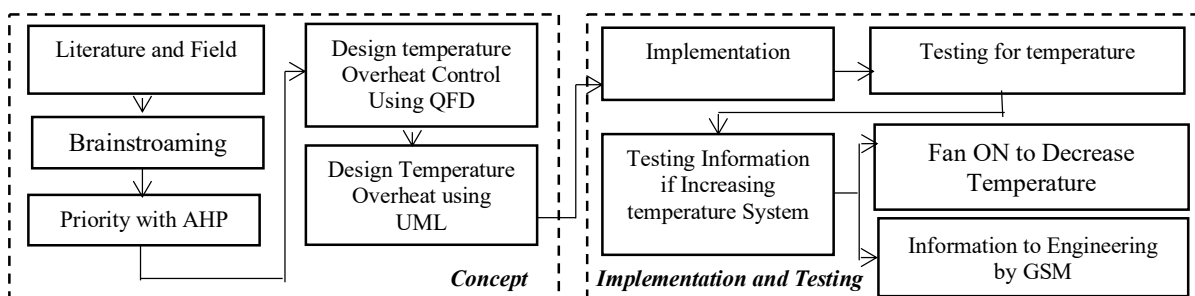

**Figure 2.** Research framework.

Based on the framework of thinking above, this research is divided into four major groups, namely 1). Problem analysis and data collection, at this stage, researchers conducted field observations to obtain information about problems in the R301 production machine at Aristek Highpolymer; the next step is to study the specifications of the R301 engine used in the production process. Information obtained from observations is that the agitator on the R301 machine can overheat and cause the engine to stop or not operate; another condition is the difficulty of knowing the real-time temperature of the R301 agitator stirrer. 2). The author planned the Agitator temperature information system tool using the Analysis Hierarchy Process (AHP), then made a list of questions to get VoC (Voice of Customer) from internal Aristek Highpolymer, which will be used as the basic criteria for designing information system tools. 3). This step is to create a product design using an information tool that can quickly notify if an overheating occurs using the UML method [6]. 4). The last stage is product implementation and product testing. At this stage, all components with program modules using the Arduino IDE (Integrated

Development Environment) are adjusted to read the R301 machine's temperature. Then the Arduino microcontroller is assembled with the GSM SIM800L module and inputs programming commands on the Arduino IDE, then the phone number to which the temperature notification will be sent via SMS. In this study, if the temperature information appears in graphs and numbers on the Thingspeak display and sends a hazard temperature notification via SMS, it means that product testing has been completed.

### 3. Result and Discussion

#### 3.1 Priority decisions with AHP

The initial stages in this research are collecting data and doing brainstorming, which is carried out together with the head of engineering, managers, and machine operators. Based on the brainstorming results, it was found that the company needed a temperature control device on the Agitator 301 machine with specifications for light equipment weight, affordable prices, easy handling, easy installation, and electrostatic requirements. From these conditions, attributes are determined according to the company's needs and then analyzed with AHP [7]. AHP analysis uses Super decision software with three experts, namely the head of engineering, manager, and machine operator, and the AHP structure is as follows.

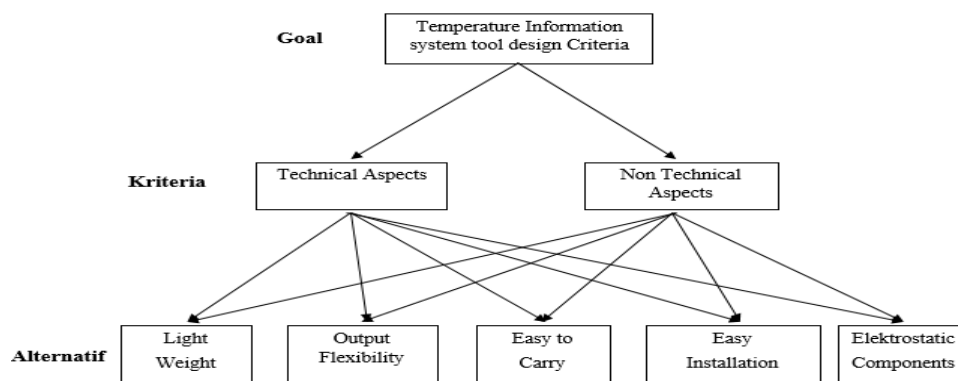

Figure 3. Structure of AHP.

Details of AHP data processing are found in this study with the Consistency Index value as in Table 1 below.

Table 1. Consistency Index Value.

Cluster	CI	N	RI	CR = CI / RI
Information System Tool Design Criteria	0.00000	2	0.00	0
Technical Aspect	0.07250	5	1.12	0.06473
Non-Technical Aspect	0.04567	5	1.12	0.04077

The table of consistency index values above shows that the experts' opinions for this study are consistent because the CI value is  $< 0.1$ . Furthermore, the results of the AHP analysis are summarized in Table 2 below.

Table 2. Results of analysis using AHP.

Graphic	Alternatives	Total	Normal	Ideal	Rank
	Light Weight	0.0329	0.0658	0.1969	5
	Output flexibility	0.0803	0.1606	0.4806	4
	Electrostatic Components	0.1278	0.2555	0.7647	2
	Easy to carry	0.0920	0.1839	0.5503	3
	Easy Installation	0.1671	0.3342	1.0000	1

The table above shows that there are four attributes with the highest ranking. According to the expert, these attributes will be used as technical aspects related to the design of the agitator safety device in this study. The criteria selected above serve as the basis for the proposed temperature information system tool to maximize the Agitator working process and prevent overheating.

### 3.2 Design Model with QFD

After the researcher conducted the analysis using AHP, the four attributes were selected in QFD. Each of these attributes has a weighted value. This weighted value will determine the Importance Value, which helps know which features are most important to the customer. The following is a list of features, weight values, importance ratings. The correlation ratio in QFD shows a measure of R301's effort in improving the sensitivity of overheating if happens. The ratio value is obtained from the criteria of experts 1 Head Engineering Aristek Highpolymer, managers and machine operators R301.

**Table 3.** Results of the questionnaire on the importance of criteria.

Attribute	Voice Qty				
	STD	TD	D	LD	SD
Output flexibility		3	3	3	1
Easy to carry	1	2	2	1	4
Electrostatic Components	2	2	3	1	1
Easy Installation		2	3	4	1

The determination of the level of interest was obtained from the results of discussions with Aristek Highpolymer's management. Determination of the level of relative importance is carried out to determine how important each respondent's criteria are. Here is the formula for calculating the importance rating as follows [8]:

$$IR = \frac{\text{the number of respondents voted} \times \text{Interest Weight}}{\text{Number of Questionnaire}}$$

The following is an example of the calculation for the first attribute, which is lightweight and easy to carry:

1. STD :  $1 \times 0 = 0$
2. TD :  $2 \times 3 = 6$
3. D :  $3 \times 2 = 6$
4. LD :  $4 \times 1 = 4$
5. SD :  $5 \times 4 = 20$

$$\text{Importance rating} = \frac{(0 + 6 + 9 + 12 + 5)}{10} = 3.2$$

After calculating the Importance rating for the first attribute, the author calculates the Importance rating for the second, third, and so on attributes. The results of these calculations are summarized in the following table.

**Table 4.** Summary of the calculation of the value of Importance Rating.

No.	Customer Needs	Importance Rating Value
1	Output flexibility	3.2
2	Easy to carry	3.5
3	Electrostatic components	2.4
4	Easy Installation	3.4

Based on the table, it shows that the attributes that have an importance rating or prioritized attributes to be realized in the temperature information system tool are based on the voices of the engineers of Aristek Highpolymer is an attribute that is easy to install and easy to carry, with an importance rating of 3.4 and 3.5.

**Table 5.** List of technical requirements.

NO	Customer Needs	Technical Needs
1	Output flexibility	Using wireless
2	Easy to carry	Case design
3	Electrostatic Components	Component design
4	Easy installation	Tool design

Relationship Matrix This matrix is useful for describing the relationship between customer requirements (customer requirements) and technical requirements (Technical requirements). The relationship is divided into four levels: no relationship, weak relationship, moderate relationship, and strong relationship. A weak or strong relationship will affect the product because it will be used in the design process. Then a table is made that contains the relationship between customer and technical needs so that the relationship between the two can be known. The relationship can be seen in the following table.

**Table 6.** Matrix of the relationship between customer demand and technical requirements.

Customer Needs	IR	Technical requirements			
		1	2	3	4
Output Flexibility	3.2	△		●	○
Easy to Carry	3.5		△	○	●
Electrostatic Components	2.4	○		△	●
Easy installation	3.4		△		○

Based on the table, it can be concluded that four relationships fall into the strong relationship category, as many as four relationships fall into the moderate relationship category, and three relationships fall into the weak relationship category. After doing and determining each relationship, the next author converts the symbol into a number to make it easier for the author to perform analysis and calculations. The following is a table of the conversion results of these relationship symbols.

This importance value corresponds to a predetermined technical need. Here is the formula used to determine the absolute importance value:

$$Kt = \sum (Bti \times Hi)$$

Information :

$Kt$  : Value of absolute importance.

$Bti$  : The weight of the value of the relative importance of the desires of consumers who have a relationship with attributes.

$Hi$  : The value of the relationship of consumer desires with attributes.

The following is an example of calculating absolute importance for the attribute “Weight of constituent components”.

$$Kt = \sum (3.2 \times 9) + (3.5 \times 0) + (2.4 \times 3) + (3.4 \times 0) = 36$$

The calculation of the absolute importance value is carried out for all technical requirements attributes. The following table contains a recapitulation of the calculation results for all technical requirements attributes.

**Table 7.** Results of absolute importance values.

No	Technical Needs	Absolute Importance Value
1	Using wireless	36
2	Case Design	62.1
3	Component design	35.5
4	Tool Design	25.7



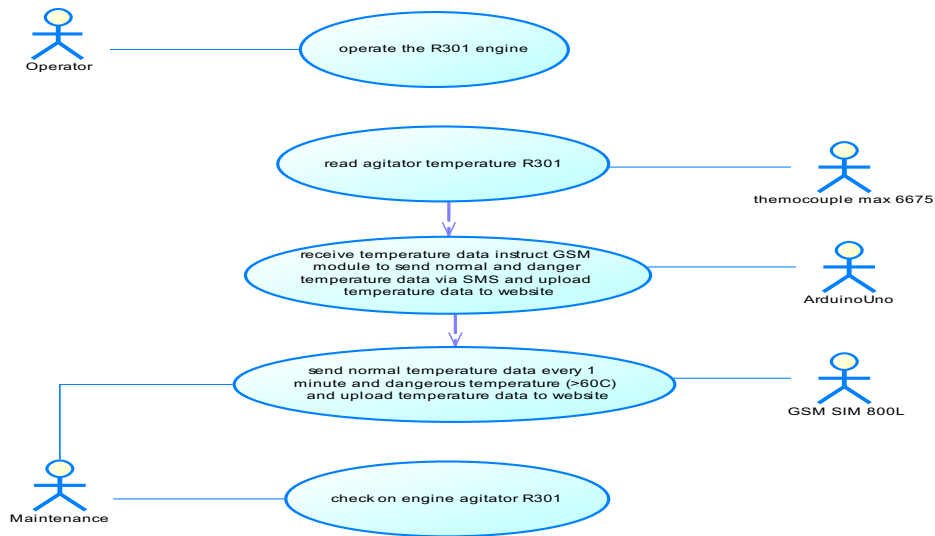

Figure 5. Use case diagram information system.

This section will explain the design of use case diagrams for monitoring applications and monitoring systems. Moreover, this section also explains how the tool works when the machine is at a dangerous temperature, the tool will send SMS notifications, at normal temperatures, the tool will send temperature data via SMS with a time frame of every 1 minute, and the tool will upload temperature data to the Thingspeak website.

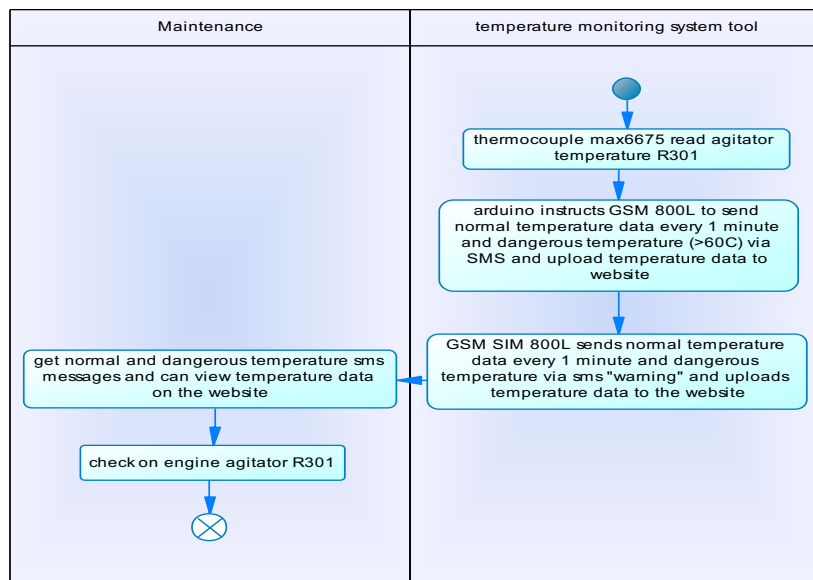
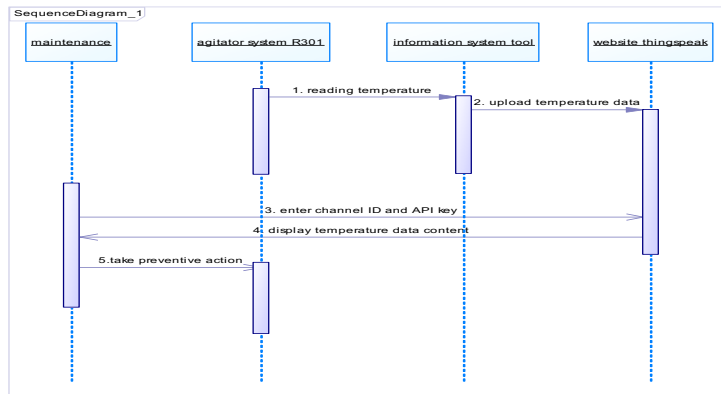

Figure 6. Activity Diagram

Activity diagrams will tell how the workflow of this information system tool and how users can receive information from this information system tool.



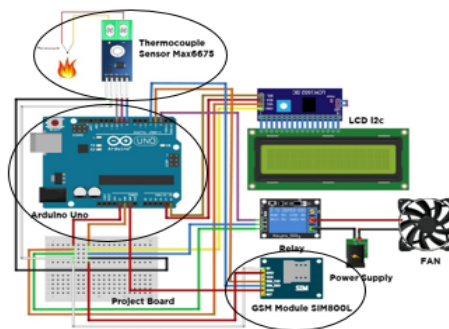

**Figure 7.** Sequence Diagram Information System

The sequence diagram in this section shows the interactions needed to see the display of temperature data information that he wants to see on the monitoring website. Figure 7 above shows that the existing system, namely the agitator system, is not disturbed by the presence of a new system or a system on the agitator temperature monitoring information system tool.

*3.4 Design Product*

The next process is designing a series of tools by connecting the Arduino parts, the Max6675 temperature sensor, and the GSM SIM 800L module using the freezing application. The following is a schematic of the Arduino port and pin circuit, the Max6675 sensor, and the 800L GSM SIM module:



**Figure 8.** Device Component Circuit Design

Based on Figure 8, the connection to the Arduino Uno microcontroller port can be seen in the two tables below.

**Table 8.** Arduino Port Connection with Sensor pin Max6675

Arduino	Sensor Max6675
GND	GND
5V	VCC
10	SCK
9	CS
8	SO

**Table 9.** Arduino Port Connection with GSM SIM pin 800L pin

Arduino	Modul GSM SIM 800L
5V	5V
GND	GND
3	SIM_TXD
4	SIM_RXD
GND	GND

The following is the Actual circuit that has been adjusted between the Arduino Uno, Thermocouple, and GSM SIM 800L ports:

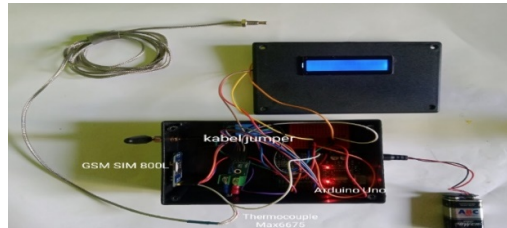

**Figure 9.** Actual Tool Component Circuit

After the components of each tool have been installed, the next step is testing the software or program where programming is significant in a system to make it fit as desired. Tools made using the Arduino Uno microcontroller require a program in the C language.

```
#include "max6675.h"
#include <LiquidCrystal_I2C.h>
#include <SoftwareSerial.h>
#include <String.h>
#define SIM800_TX_PIN 3
#define SIM800_RX_PIN 4

SoftwareSerial serialSIM800(SIM800_TX_PIN, SIM800_RX_PIN);
String Write_API_key = "666RB056YQXKETWC"; // Thingspeak Write API Key
String apn = "3gprs";

int ktcSO = 8;
int ktcCS = 9;
int ktcCLK = 10;
float data;
float data1;
MAX6675 ktc(ktcCLK, ktcCS, ktcSO);
LiquidCrystal_I2C lcd(0x27, 20, 4);

void setup() {
  lcd.init();
  lcd.backlight();
  lcd.setCursor(0, 0);
  lcd.print("Temperature R301");
  lcd.write(0);
  Serial.begin(9600);
  pinMode(2, OUTPUT);
  while(!Serial);
}

data1 = ktc.readCelsius();
Serial.begin(9600);
while(!Serial);
}

void loop() {
  SetupModule();
```

**Figure 10.** Arduino Program.

After the Arduino program process is complete, the program is uploaded to the Arduino Uno.

### 3.5 Program Test Results

After the program is uploaded to the Arduino microcontroller, it is checked that it is running as desired on the serial monitor. In a system design where sending SMS and uploading temperature data to the website via a GSM SIM 800L module that has been installed with a phone card (GSM SIM card) that has been filled with credit and has internet data.

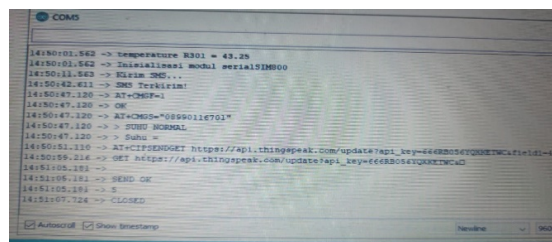

**Figure 11.** Control information in the monitor.

In Figure 11, a description of sending an SMS is displayed, and after that, it displays a description of the SMS sent. Based on Figure 11, it can also be seen that the sending of temperature data to the Thingspeak channel website has been successful with a statement on the serial monitor that says SEND OK.

From the results of the application, it is known that the tool made can measure temperature precisely, and this can be seen in the table below.

**Table 10.** Test results of the direct tool and machine thermo-gun R301.

No	Thermogun Temperature (°C)	Tool temperature (°C)	Testing Time
1	34.75	35.50	10:28
2	34.10	34.50	10:29
3	33.75	34.75	10:31
4	36.25	36.25	10:33
5	29.85	30.00	11:34
6	28.10	29.25	11:35
7	29.00	29.75	11:41
8	33.60	29.50	11:45
9	28.20	30.25	13:49
10	29.10	29.25	11:58

The test is carried out by placing the designed tool on the R301 agitator machine. Then, the test results' temperature is compared with a thermo-gun. The test results obtained the difference in the average temperature value of about 1 °C - 2.5 °C between the tools made with the thermo-gun. The application results show that the temperature rise information can be known more quickly and accurately so that the problem of engine damage due to the increase in engine temperature on the agitator can be well controlled.

#### 4. Conclusion

The design of the temperature control device on the R301 agitator to prevent overheating using QFD and UML by applying the Arduino Uno, Max6675, and GSM SIM 800L temperature sensors using the Frinzing application can produce a temperature measuring device that can provide information quickly. This tool will notify if the engine temperature exceeds the maximum limit, above 60°C. In addition to providing reports on these conditions, this tool can also turn on the fan used to reduce heat in the motor of the mixer machine so that this tool significantly reduces the risk of loss due to engine failure and engine damage. This research provides an opportunity for further research on the R301 engine in the form of a viscosity controller, pressure gauge, and overall engine redesign by paying attention to sensor-based occupational safety and health to prevent losses due to fire and work accidents.

#### 5. References

- [1] Stoyanova M, Nikoloudakis Y, Panagiotakis S, Pallis E and Markakis E K 2020 A Survey on the Internet of Things (IoT) forensics: Challenges, approaches, and open Issues *IEEE Commun. Surv. Tutorials* **22** 1191–1221
- [2] Injadat M N, Moubayed A and Shami A 2020 Detecting botnet attacks in IoT environments: An optimized machine learning approach *Proc. Int. Conf. Microelectron. ICM 2020-Decem*
- [3] Mahdi M J, Aljuboori A F and Hussein A M 2021 Smart stadium using cloud computing and Internet of Things (IoT): Existing and new models *Int. J. Comput. Appl. Technol. Res.* **10** 111–118
- [4] Chen R Y 2013 Intelligent service-integrated platform based on IOT technology using FCM and FQFD method *2013 IEEE 6th Int. Conf. Adv. Infocomm Technol. ICAIT 2013* 151–152
- [5] Ganesh E N 2017 Implementation of IoT architecture for smart home using GSM technology *Int. J. Comput. Tech.* **4** 42–48
- [6] Poongodi T, Rathee A, Indrakumari R and Suresh P 2019 *IoT sensing capabilities: Sensor deployment and node discovery, wearable sensors, wireless body area network (WBAN), data acquisition* **174**
- [7] Taha H A 2017 *Operation Research an Introduction* Tenth Edit Pearson
- [8] Deepu T S and Ravi V 2020 An integrated ANP–QFD approach for prioritization of customer and design requirements for digitalization in an electronic supply chain *Benchmarking*
- [9] Huang A, Cao J and Zhang H 2020 Construction of patient service system based on QFD in internet of things *J. Supercomput.* 0123456789
- [10] Ahmadzadeh A, Sheikh A A, Shahin A and Teimouri H 2020 Developing a QFD model for prioritizing the CSFs of ERP based on the enablers of organizational agility *Benchmarking*

2008.

- [11] Tseng F M *et al.* 2018 Integrating Service QFD and TRIZ for a lucky draw system design: The case study *Proc. - 2017 IEEE 7th Int. Symp. Cloud Serv. Comput. SC2 2017* **2018-January** 189–193
- [12] Li F, Chen C H, Lee C H and Khoo L P 2020 A user requirement-driven approach incorporating TRIZ and QFD for designing a smart vessel alarm system to reduce alarm fatigue *J. Navig.* **73** 212–232
- [13] Aloui A and Grissa A 2015 *Computational Intelligence Applications in Modeling and Control* **575**