

Performance in Organisational Behaviour: Strength of Work Discipline and Employee External Motivation

Asep Irfan Permana¹, Anton Wachidin Widjaja², Zahara Tussoleha Rony³ and Irma Setyawati⁴

**¹Master of Management Department, Universitas Bhayangkara Jakarta Raya
Jakarta, DKI Jakarta, Indonesia
*asep.irfanpermana@yahoo.co.id***

**²Master of Management Department, Universitas Bhayangkara Jakarta Raya
Jakarta, DKI Jakarta, Indonesia
*anton.wachidin@dsn.ubharajaya.ac.id***

**³Education of Elementary School Department, Universitas Bhayangkara Jakarta
Raya, Jakarta, DKI Jakarta, Indonesia
*zahara.tussoleha@dsn.ubharajaya.ac.id***

**⁴Master of Management Department, Universitas Bhayangkara Jakarta Raya
Jakarta, DKI Jakarta, Indonesia
*irma.setyawati@ubharajaya.ac.id***

Abstract

In principle, operating companies have continued expectations of financial and non-financial developments that are supported by human resources performance in organisational behaviour. Analysing phenomenon, this study aims to examine organisational behaviour, namely global leadership, work discipline and external motivation on improving employee performance. Experimental research was carried out through case studies on employees of PT. Ispat Bukit Baja Bekasi. A total of 69 employees were involved in filling through a quantitative questionnaire, by analysing data through Structural Equation Model. The results of the study conveyed that work discipline and external motivation are employee behaviours that are able to improve employee performance, in contrast to global leadership. However, the role of leadership in providing direction and giving examples in behaving act as a key performance indicator of the company. Work discipline and external motivation need to be used by management to strengthen organisational guidelines. In the end, important organisational behaviour is considered by the company, in relation to the performance of the company.

Keywords: Global Leadership, Work Discipline, External Motivation, Employee Performance

1. Introduction

International companies need global managers who have the ability to transfer technology to local cultures, manage local staff and adapt business practices according to local

conditions (Tiina Jokinen, 2005). Global leadership is a new concept that leads to the evolution of multinational companies into entities that are not bound by the state, which are currently moving rapidly with operations covering the entire world. Individuals make significant positive changes in the organisation by building communities through developing trust and regulation of organisational structures and processes in contexts involving various stakeholders across borders, various sources of external cross-border authority, and diverse cultures under conditions of temporal, geographical and cultural complexity (Bird & Mendenhall, 2016). Leadership is always identified with management, whereas in terms of practice is different. Management concerns matters concerning planning, organising, actuating and controlling while leadership is more about overcoming changes (Thorn, 2012).

Work discipline is a tool used by managers to communicate with employees to change behaviour and efforts to increase one's awareness and willingness to comply with all applicable company regulations and social norms. Sequence is the main characteristics of the organisation and discipline is one method to maintain that order (Batara, Fathoni, & Minarsih, 2019). The main purpose of the discipline is to increase efficiency as much as possible by preventing waste of time and energy. In addition, the discipline seeks to prevent damage or loss of property, machinery, equipment and work equipment caused by negligence, banter or theft (Abrams & Nolan, 2006). Discipline tries to overcome mistakes and negligence caused by lack of attention, disability, and delay. Discipline strives to prevent the emergence of work that is slow or open at the beginning of work due to delay or laziness. Discipline also seeks to overcome dissent among employees and prevent non-compliance caused by misunderstandings and misinterpretations.

Literally, the term motivation comes from the Latin word *movere*, which means moving which shows a process that begins with a physiological or psychological deficiency that drives behaviour or impulse that is indicated for purpose or incentive, so to understand the process of motivation depends on understanding and the relationship between needs, encouragement, and incentives (Setyawati, 2013).

According to Kuvaas, Buch, Weibel, Dysvik and Nerstad (2017), motivation is often interpreted as a driving factor for someone's behaviour, and the driving factor is none other than a person's needs and desires to carry out an activity. If someone wants something, then he will be compelled to do certain activities to get what he needs. In a company, motivation is very necessary, both motivation from superiors and motivation that rise from themselves (Georgeon et al., 2016).

The study aims to examine organisational behaviour, namely global leadership, work discipline and external motivation on improving employee performance in PT. Ispat Bukit Baja Bekasi.

2. Literature Review

2.1 Global Leadership

Leadership is not just an expression of a position in the hierarchy or chain of command. So, leadership is defined as a form of ability that influences and a type of interaction between the initiative taker and a follower. It is also defined as the ability to influence a

group towards achieving goals. In practice, leadership establishes the vision that will be achieved and communicates it to the group so that it can be implemented. Management plays an important role in terms of realising the vision made by the leader. Thus, there are similar roles and leadership competencies between global leaders and domestic leaders (Bird & Mendenhall, 2016; Thorn, 2012). The leaders of all organisations will face challenges to lead on the global stage. People from various backgrounds, languages, beliefs, and mindsets move around the world. So, developing a leader who is able to handle diversity is very important for all organisations. A diverse environment provides opportunities for critical understanding of differences and enhancing corporate culture (Tubbs & Business, 2006). Globalisation has increased complexity and ambiguity in organisations. Global leaders need to develop their skills, knowledge and leadership abilities in a multicultural environment with various groups. Keefe (2018) identifies a global mindset as "the ability to influence individuals, groups, organisations, and systems that have intellectual, social and psychological knowledge or intelligence that is different from yours".

2.2. Work Discipline

Work discipline according to Abrams and Nolan (2006) , is interpreted as follows: "A person's awareness and willingness to obey all company rules and prevailing social norms. Another opinion about disciplinary factors that affect performance was stated by Mangkunegara and Octorend (2015), who stated that personal factors, indicated by the level of skill, competence, motivation, and individual commitment. Individual commitment is a great desire to work and can be realised with discipline. According to Akbar Dwi Permana and Putra (2016), discipline is the awareness and willingness of employees to comply with all applicable company rules and social norms. Discipline shows a condition or respect that is in the employee's rules and regulations. According to Harley, Sargent, and Allen (2010), a good form of discipline will be reflected in the atmosphere, namely:

- a) The high sense of care of employees towards achieving company goals.
- b) The high enthusiasm and passion of work and the initiative of the employees in doing work
- c) The amount of responsibility of employees to carry out their duties as well as possible
- d) The development of a sense of belonging and a high sense of solidarity among employees.
- e) Increased efficiency and work productivity of employees

Discipline action for employees must be the same as its implementation. Here the disciplinary action applies to all, does not choose, sort out and side with anyone who violates will be subject to disciplinary sanctions that are the same including for managers or leaders, because leaders must set an example for their subordinates. According to Mangkunegara and Octorend (2015), the form of work discipline is: Realizing organisational goals based on agreed plans.

2.3. External Motivation

In a company, motivation is very necessary, both motivation from superiors and motivations that rise from themselves. To work together for the interests of the company without motivation, the goals set will not be achieved because the motivation to work is

very influential for the high and low productivity of the company. Kuvaas et al (2017) defined that motivation as a process that takes into account the intensity of one's direction and perseverance towards achieving goals, while general motivation is related to efforts towards any goal, motivation to work is very important for the high and low productivity of the company. According to Georgeon et al. (2016), one's work motivation is influenced by external factors, namely factors that come from outside the individual such as promotion, rewards, salary, working conditions, company policies, and jobs that contain responsibility.

Employees will be motivated if there is support from management and a conducive work environment which in turn has an impact on job satisfaction. Meanwhile UNTARI, AVENZORA, DARUSMAN, PRIHATNO, & ARIEF (2018) suggests that one's work motivation is influenced by system needs, such as: a). Leader, b). Coworkers or social world, c). Physical facilities, d). Policies and regulations, e). Rewards for money and non-money services, f). Types of work and challenges.

2.4. Employee performance

Performance is a real behaviour displayed by everyone as the work performance produced by employees in accordance with their role in the company Akbar Dwi Permana and Putra (2016). Performance actually has a broader meaning, not only work, but also covers how the work process takes place. Performance is the result of work that has a strong relationship with the organisation's strategic goals, satisfaction and contribution to the company. Performance is about what to do and how to do it. According to Harley et al. (2010), to measure the performance of an employee there are five criteria that result from his work, namely:

- a) Quality, Quality is the degree to which the final results achieved are near perfect in the sense of meeting the expected goals
- b) Quantity, Quantity is the amount produced which is expressed in terms of a number of work units or is the number of cycles produced.
- c) Timeliness, the level of activity completed by the work at the desired initial time.
- d) Effectiveness, Effectiveness is the level of knowledge of organisational resources in order to increase profits.
- e) Independence, Employees can perform their work functions without assistance from others.

3. Research Method

3.1 Samples and Data Analysis

This research was included in an experimental study with a case study at PT Ispat Bukit Baja. The population taken was 69 maintenance employees at PT Ispat Bukit Baja. The research method in this study is a quantitative research method using the PLS-SEM program. Data collection is done by using a questionnaire, that is a method of collecting data by giving or distributing a list of statements to respondents.

3.2. Hypothesis

In this study explained the alleged relationship between exogenous variables namely Global Leadership (GL), Work Discipline (WD) and External Motivation (EM), endogenous

variables namely Employee Performance (EP). Schematically, this can be illustrated in Figure 1.

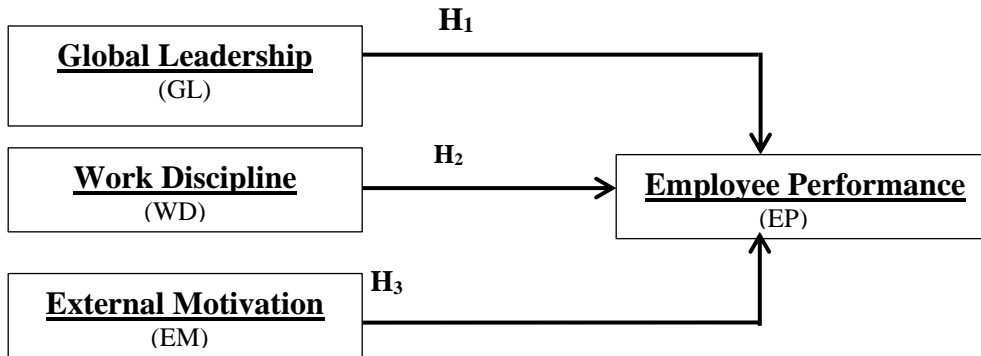

Figure 1: Thinking Framework

Examining Figure 1, the design of the research hypothesis is presented as follows:

- H₁ : Global Leadership can influence Employee Performance
- H₂ : Work Discipline can influence Employee Performance
- H₃ : External Motivation can influence Employee Performance

4. Result and Discussion

In testing the instruments and hypotheses in this study using the help of SEM-PLS software, there are several steps that must be analysed from data processing, the processed data is presented in Figure 2.

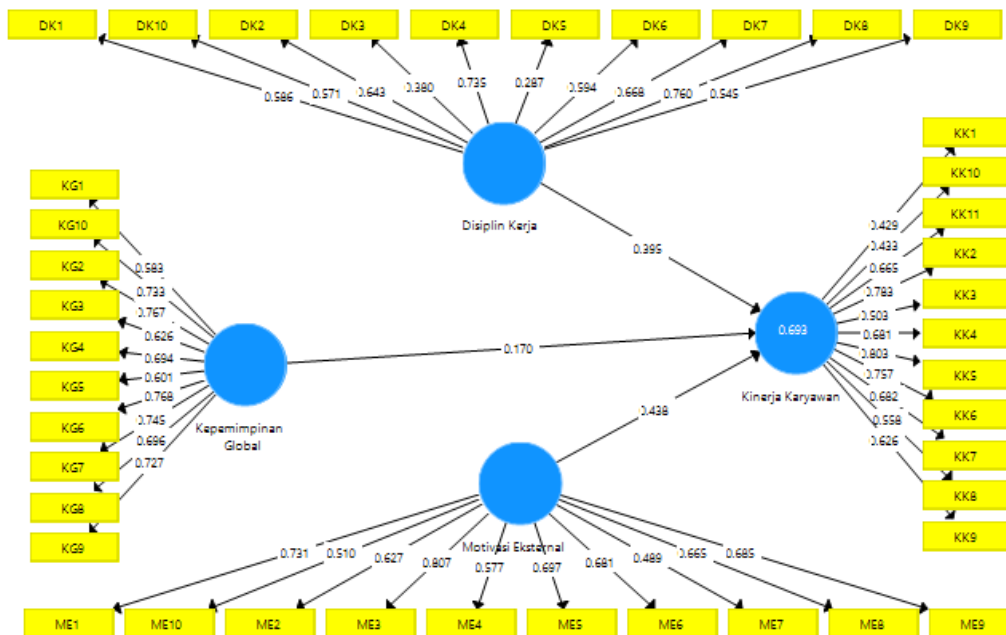

Figure 2: Design of the Research Structure Model

Below is the result of the process of reducing several indicators that do not behave in support of the formation of the Cronbach's Alfa value, and composite reliability above the AVE criteria > 0.5. Where this is very important as an indication that the construct has been declared reliable for further analysis, this is illustrated in Figure 3.

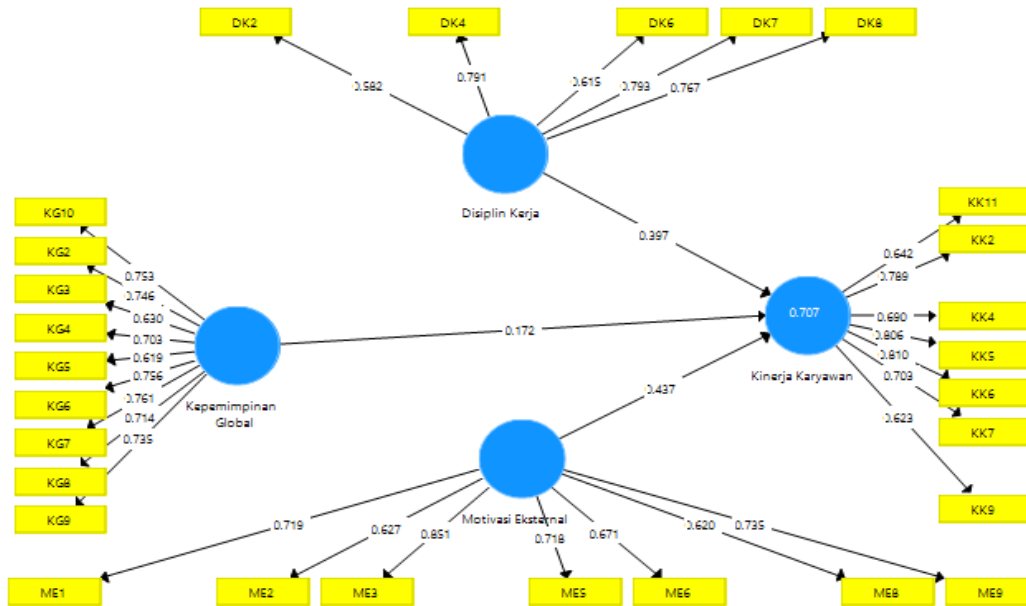

Figure 3: Structure of Modified Results Model

The next step is to process data that supports the structural model by performing an algorithm process. From the algorithm process, the information obtained is information on the construct of reliability and validity as presented in Table 1.

Table 1: Validity and Reliability Test Results

Matrix	Cronbach's Alpha	Rho_A	Composite Reliability	Average Variance Extracted
Work Discipline	0.802	0.810	0.857	0.501
Global Leadership	0.924	0.942	0.936	0.596
Employee Performance	0.881	0.890	0.905	0.516
External Motivation	0.878	0.905	0.901	0.508

After the agreement was stated to be reliable and valid, it was followed by a structural model testing. This test is intended to get results that can be used to test predetermined hypotheses. The evaluation of the structural test results of the model aimed at obtaining your reference determines the ability of the model to predict one or more target constructs. The first step that must be done is the bootstrap process in the SmartPLS programme for the structural design of the model. The following is a picture of the structure of the research model from the Bootstrapping process in the SmartPLS program. Figure 4 shows the structure of the bootstrap results research model.

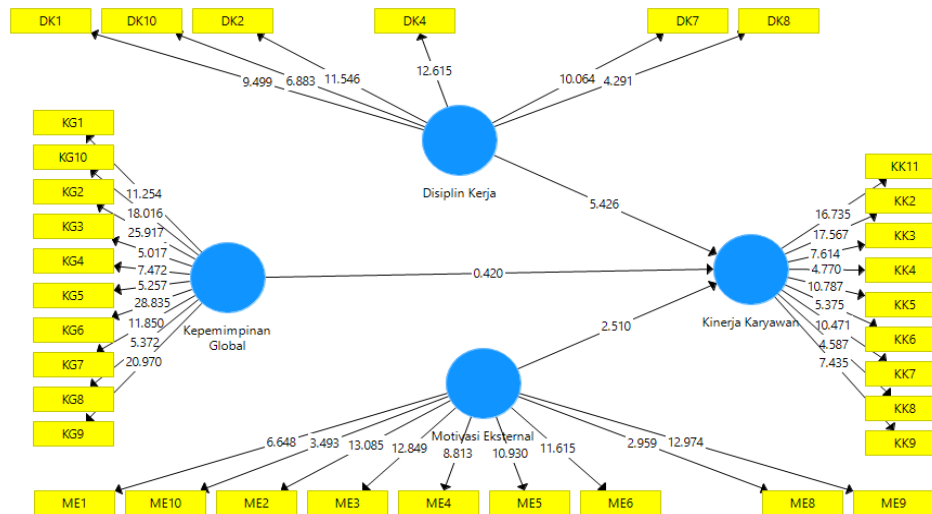

Figure 4: Structure of the Bootstrap Results Research Model

Figure 4 contains information that is very important, namely the path coefficient of each relationship between constructs. As an example; path coefficient between constructs of work discipline towards employee performance as contract target of 5,428. The path coefficient is an indication of the significance of the relationship between work discipline to employee performance. Declare the relationship of constructs of significant work discipline to employee performance? This needs to be tested, by comparing it to the criteria of significance.

The next step is to determine whether a structural design model is feasible to be used as a tool to analyse hypotheses. Several tests must be carried out, including construct colinearity test, significance test, and others. Following is the testing process. The criteria for testing colinearity is the value of Variance Inflation Factor (VIF). Colinearity test is prioritised when the type of outer model / measurement model is formative. So, in this study, the priority of the colinearity test was not prioritised, because the type of the outer model in this study was reflective. In processing data with a reflective type measurement model, it is considered that there is no problem of collinearity. Collinearity criteria are VIF values must be smaller or equal to five (5), (VIF <5). If we are curious to prove that the construct design of this research does not have a problem of collinearity, please see Table 2.

Table 2: Results of Collinearity Statistics

Outer VIF Values	Inner VIF Values			
	Work Discipline	Global Leadership	Employee Performance	External Motivation
Work Discipline			1.520	
Global Leadership			2.575	
Employee Performance				
External Motivation			2.608	

Path coefficient testing is done by comparing the coefficient relationship of each construct/variable with the value of the T-value set. T-value to test the significance of the relationship between constructs was determined at 1.2946 (Coefficient Path (T) > 1.2946 declared significant). The T-Statistic value as a parameter of significance relates to each predictor variable with the target variable determined according to Table 3.

Table 3: T-Value

Path	Path Coefficient	T-Value Criteria	Result Test	Significant	P-Value	P-Value Criteria	Result Test	Significant
WD to EP	5.426	> 1.295	Fulfilled	Yes	0.0000	< 0.05	Fulfilled	Yes
GL to EP	0.420	> 1.295	Un fulfilled	No	0.674	< 0.05	Un fulfilled	No
EM to EP	2.510	> 1.295	Fulfilled	Yes	0.012	< 0.05	Fulfilled	Yes

From Table 3, it is found that the T-value of each relationship between predictor variables and the target variabls has a significant relationship. For example, the path coefficient between WD, has a path coefficient of 5.426 for the EP construct. The path value of the correlation coefficient between WD is greater than T-value (1.2946). Thus, the relationship between the two constructs is concluded to be significant. Likewise the relationship between EM and EP is significant with the path coefficient P-value 2.510 > 1.2946.

The level of significance of the relationship between the two constructs is also determined by the path coefficient value, can also be determined by the p-value, wherethe criteria for p-value must be smaller than 0.05 (p-value < 0.05). This terminated coefficient serves to assess the level of accuracy of predictions towards endogenous constructs. The criteria are qualitative values, substantial, moderate, and weak.

Assessing high, medium, and weak accuracy is very difficult. Thus Hair, Ringle and Sarstedt (2011) also Hensler (2009) provide a score commonly used in marketing studies, where the value of R² > 0.75 has a high predictive accuracy, R² > 0.5 has a medium prediction accuracy level, and R² > 0.25 has a weak predictive level. In this research construct, R² is obtained as in Table 4.

Table 4: Value of R²

Construct Endogen	Value of R ²	Criteria	Level of accuracy	Accuracy of predictions
Employee performance	0.674	Not 0 and Max 1	> 0.20, weak > 0.50, moderate > 0.70, substantial	Moderate

The above test results state that the accuracy of EP predictions is a construct target of WD, GL and EM. As a predictor construct with moderate accuracy, R² whose value is 0.674 greater than 0.5, is an indication that employee performance has a moderate prediction accuracy rate.

In addition to measuring the R2 of an endogenous variable, effect size f^2 is needed to measure the power/influence of each predictor construct on its target construct, the indication is seen from the change in R2 value when the predictor container is omitted. Criterial effect size (f^2) is in the form of qualitative values in the small, medium, and influential categories. Cohen (1998) gives a guide The value of influence f^2 is said to be small when the value is > 0.02 , the medium value is > 0.15 , and has a large effect when the value is > 0.35 . Table 5 shows the clarity test results.

Table 5: Clarity Test Results

Construct	Employee Performance	Criteria	Test Result
Work Discipline	0.763	> 0.02 Weak > 0.15 Moderate > 0.035 Substantial	Work discipline predicts employee performance to be substantial
Global Leadership	0.008	> 0.02 Weak > 0.15 Moderate > 0.035 Substantial	Global leadership predicts employee performance to be weak
External Motivation	0.162	> 0.02 Weak > 0.15 Moderate > 0.035 Substantial	ME predicts employee performance to be moderate

In the summary of the effect size (f^2) test results above, it is concluded that each predictor variable has a certain level of influence (weak, moderate, substantial) on the target variable. This is done by looking at changes in the determinant coefficient, R2 when one of the predictor variables is omitted. As an example; work discipline which represents constructs can change the value of R2 from employee performance with the level moderate. This means that the level of accuracy of the predictive power of the target construct, employee performance, is influenced by the work discipline predictor variable with a strong effect. Work discipline predicts employee performance substantially.

This hypothesis is part of a series of research processes to prove the truth of the prescribed hypotheses. Furthermore, the results of this hypothesis testing will be used to analyse the influence of global leadership, work discipline, external motivation on the performance of maintenance employees at PT Ispat Bukit Baja Bekasi. The series of testing of this hypothesis is to prove that the Employee Performance of the maintenance section at PT Ispat Bukit Baja Bekasi is influenced by Work Discipline and External Motivation

H1.1: Global leadership influences the employee performance of maintenance section in PT Ispat Bukit Baja

H1.0: Global leadership does not have an effect on the employee performance at the maintenance section of PT Ispat Bukit Baja

From the results of data processing, it was found that the coefficient of significance (path coefficient), the relationship between constructs of global leadership and employee

performance T-value was set at 1.2946. Because the coefficient of significance of global leadership with employee leadership is 0.420 (< 1.2946), the hypothesis, H1-1 is rejected, means that global leadership does not affect employee performance.

H2-1: Work discipline affects the employee performance of maintenance section at PT Ispat Bukit Baja Bekasi

H2-0: Work discipline affects the employee performance of the maintenance section at PT Ispat Bukit Baja

The significance coefficient of the relationship between constructs of work discipline and employee performance is 5.426. The T-value is set at 1.2946 because the work discipline significance coefficient for employee performance is 5.426 and the value is greater than 1.2946 (> 1.2946), then the hypothesis is accepted. Work discipline has a significant influence on employee performance.

H3-1: External motivation affects the employee performance of maintenance section at PT Ispat Bukit Baja Bekasi

H3-0: External motivation affects the employee performance of maintenance section at PT Ispat Bukit Baja Bekasi

The results of the statistical process, the coefficient of the relationship between the constructs of external motivation and employee performance is 2,510. The T-value is set at 1.2958. Because the coefficient of the relationship between external motivation to employee performance is 2.510, and the value is greater than the T-value of 1.2946 (> 1.2946), it is concluded that (H3-1) is accepted. This means that the alleged employee performance is influenced by external motivation.

5. Conclusion

Based on the results of the analysis of the discussion of the data, the authors obtained conclusions that can be drawn from the research on the Influence of global leadership, work discipline and external motivation on employee performance of the maintenance section at PT Ispat Bukit Baja Bekasi. From the conclusions outlined, the researcher proposes several suggestions with great expectations that can be considered as an effort to improve the performance of employees at PT Ispat Bukit Baja, so that the future employee performance will be better. The global leadership variable proved to be insignificant towards the variable performance of maintenance department employees at PT Ispat Bukit Baja Bekasi. Work discipline variables proved significant to the variable employee performance at the maintenance section of PT Ispat Bukit Baja Bekasi. The external motivation variable proved to be significant towards the variable. Performance of the maintenance staff at PT Ispat Bukit Baja Bekasi. Based on the results of this study, PT Ispat Bukit Baja could focus on improving activities. Work discipline and external motivation could be viewed as a first step to improve employee performance. This can be seen from the high level of mediation of work discipline and external motivation on employee performance.

References

- Abrams, R. I., & Nolan, D. R. (2006). Toward a Theory of “Just Cause” in Employee Discipline Cases. *Duke Law Journal*, 1985(3/4), 594.
- Akbar Dwi Permana, & Putra, B. A. (2016). The Effect of Transformational Leadership and Job Satisfaction on Employee Performance. *Universal Journal of Management*, 4(4), 189–195. <https://doi.org/10.13189/ujm.2016.040404>
- Batara, Jr. S., Fathoni, A., & Minarsih, M. M. (2019). EFFECT OF WORK EXPERIENCE, WORK DISCIPLINE, AND WORK ENVIRONMENT ON WORK PRODUCTIVITY TO INCREASE WORK LOYALTY IN PT. INDEX TRANSPORTAMA. *Journal of Management*, (7), 117–118.
- Bird, A., & Mendenhall, M. E. (2016). From cross-cultural management to global leadership: Evolution and adaptation. *Journal of World Business*, 51(1), 115–126. <https://doi.org/10.1016/j.jwb.2015.10.005>
- Georgeon, O., Marshall, J., Gay, S., Georgeon, O., Marshall, J., Gay, S., ... Gay, S. (2016). *Interactional Motivation in Artificial Systems : Between Extrinsic and Intrinsic Motivation To cite this version : Interactional Motivation in Artificial Systems : Between Extrinsic and Intrinsic Motivation*.
- Harley, B., Sargent, L., & Allen, B. (2010). Employee responses to “high performance work system” practices: An empirical test of the disciplined worker thesis. *Work, Employment and Society*, 24(4), 740–760. <https://doi.org/10.1177/0950017010380638>
- Keefe, S. A. O. (2018). *The Development and Initial Validation of a Self- Assessment for Global Leadership Competencies*.
- Kuvaas, B., Buch, R., Weibel, A., Dysvik, A., & Nerstad, C. G. L. (2017). Do intrinsic and extrinsic motivation relate differently to employee outcomes? *Journal of Economic Psychology*, 61(March 2018), 244–258.
- Mangkunegara, A. P., & Octorend, T. R. (2015). Effect of Work Discipline, Work Motivation and Job Satisfaction on Employee Organisational Commitment in the Company (Case Study in PT. Dada Indonesia). *Universal Journal of Management*, 3(8), 318–328. <https://doi.org/10.13189/ujm.2015.030803>
- Setyawati, I. (2013). Tinjauan Logis dan Filosofis tentang Competitive Advantage. *Mediastima*, 10(1), 69–91.
- Thorn, I. M. (2012). Leadership in international organisations: Global leadership competencies. *The Psychologist-Manager Journal*, 15(3), 158–163.
- Tiina Jokinen. (2005). Global leadership competencies: a review and discussion. *Journal of European Industrial Training*, 29(3), 199–216.
- Tubbs, S., & Business, E. S. (2006). Exploring a taxonomy of global leadership competencies and meta-competencies. *The Journal of American Academy of Business*, 2, 29–35. Retrieved from <http://citeseerx.ist.psu.edu/viewdoc/download?doi=10.1.1.473.9266&rep=rep1&type=pdf>

UNTARI, D. T., AVENZORA, R., DARUSMAN, D., PRIHATNO, J., & ARIEF, H. (2018).
Betawi Traditional Culinary; Reflection The History Of Jakarta (Formerly Known As
Batavia). *Journal of Economic Development, Environment and People*, 6(4), 64.
<https://doi.org/10.26458/jedep.v6i4.554>