

THE EFFECT OF INNOVATION ON BUSINESS COMPETITIVENESS OF SMALL AND MEDIUM ENTERPRISE IN INDONESIA

by Turnitin Indonesia

Submission date: 25-Dec-2023 07:46AM (UTC-0800)

Submission ID: 2264771142

File name: Artikel_ProSIDing_ICOI_2019.pdf (2.19M)

Word count: 2941

Character count: 16445

THE EFFECT OF INNOVATION ON BUSINESS COMPETITIVENESS OF SMALL AND MEDIUM ENTERPRISE IN INDONESIA

Yayan Hendayana (As-Syafi'iyah Islamic University / Student Program Doctoral Management Science Indonesia University of Education, Bandung, Indonesia)

Suryana (Indonesia University of Education, Bandung, Indonesia)

Eng Ahman (Indonesia University of Education, Bandung, Indonesia)

Hari Mulyadi (Indonesia University of Education, Bandung, Indonesia)

Email : Yayan_ha@student.upi.edu; suryana@upi.edu; eengahman@upi.edu; harimulyadi@upi.edu

Abstract—This study examines the effect of innovation on the competitiveness of the handicraft sector creative industries in Indonesia. The number of samples was taken as many as 205 SMEs spread in West Java in a proportional random manner. The technique of data collection is done by the questionnaire directly to the respondents. The data analysis technique in this study is a structural equation model (SEM) approach. The use of SEM allows researchers to test the validity and reliability of research instruments, confirming the accuracy of the model while testing the effect of innovation variables on competitiveness variables. The statistical tool used in this study is AMOS version 23. The findings reveal that innovation has a significant positive effect on the competitiveness of SMEs. This study shows that innovation is an important factor that can increase competitiveness. Companies that are able to innovate appropriately will be able to compete with other companies.

Keywords: Innovation, Competitiveness, Small and Medium Enterprises (SMEs)

I. INTRODUCTION

Small and Medium Enterprises (SMEs) have a strategic role in economic growth, employment and in distributing the results of development that has been achieved. Not only in Indonesia which is a developing country, but SMEs are also the core of future economic growth in developed countries that are members of the Organization For Economic Co-Operation And Development (OECD 2000).

However, with this huge contribution, currently, Indonesian SMEs are still faced with the problem of the weak competitiveness of imported products. According to a report released by the World Economic Forum (WEF) in 2016, Indonesia's competitiveness is still below ASEAN countries such as; Singapore,

Malaysia, and Thailand. Low competitiveness influences the long-term existence of a company (Metekohy, 2013) so that overall it will have an impact on the national economy.

Strengthening business competitiveness can be done by means of internal improvements, namely through innovation. The results of the research (Gronum, Verreynne, & Kastle, 2012) found that there was an innovative contribution to the competitiveness of SMEs. According to Osterle, Hubert, et.al (2001) Only innovative companies can contribute to a company's competitiveness. Kuratko & Howard Frederick (2016) states that companies based on innovation can affect competitiveness.

This research is very important and interesting to study because so far not many have conducted research on the influence of innovation on the competitiveness of SMEs in Indonesia. A questioner survey was conducted on 205 handicraft sector SMEs scattered in West Java. The purpose of this study was to determine the effect of innovation on the competitiveness of SMEs in the craft sector.

II. LITERATURE REVIEW

A. Competitiveness

Competitiveness is the ability of a company to compete with other companies. Competitiveness is the level of productivity which is interpreted as output produced by a workforce (Porter 1990). Competitiveness is a measure of competitiveness that is formulated as the company's ability to generate profits in a sustainable manner and continue to grow. (Joewono, 2006). According to U.S. Presidential Commission on Industrial Competitiveness, 1993 in (Nabi & Luthria, 2002) *Competitiveness is the ability to produce goods and services to meet the test of international markets while simultaneously maintaining and expanding the real incomes of citizens.* There are several factors that can affect the

competitiveness of a company. According to (Schwab, 2010) innovation is one of the factors that influence a company's competitiveness. Meanwhile, according to Osterle, Hubert, et.al (2001), the determinants of a company's competitiveness are innovation and business networks. Innovation is a factor that can increase competitiveness (OECD, 2001). While according to Kuratko & Howard Frederick, (2016) states that companies based on innovation can be a driving factor for competitiveness.

B. Innovation

Innovation can be interpreted as a new discovery that is different from what already exists or that has been known before. Innovation is needed in a business because it can provide competitiveness for the company. Innovations can be products, methods, and so on that are felt like something new. According to Kotler and Keller (2009), innovation is a product, service, idea, and a new perception from someone. While according to Terziowski (2007) Innovation is the application of resources to create value for customers and companies by developing, repairing and commercializing new and existing products, processes and services. According to Chursin & Vlasov (2017) calling innovation is the realization of business operations whose main function is to carry out production reforms through the use of innovative ideas and sources to create new products (or produce old products using new manufacturing methods) and find new resources for products, markets, distribution, etc., namely rearranging the main factors of production or patterns of innovation.

C. The Relationship Between Innovation and Competitiveness

Schwab (2010) states that a company's competitiveness is influenced by innovation. Innovation is very important because knowledge can be obtained by innovation and can integrate and adapt to technological developments. Innovation is a factor that can increase competitiveness (OECD, 2001). Sementarara (Kuratko & Howard Frederick, 2016) mentions that economic drivers, economic efficiency and innovation-based as a driving factor of competitiveness. According to Thomas W. Zimmerer (2008) That, product innovation is a potential thing to create the thoughts and imagination of people who ultimately create customers.

(Chursin & Vlasov, 2017) mention that innovation is the basis for competitiveness. The higher the innovation that can be created by a company, the higher the competitiveness. This shows that innovation is a guarantee for a company or organization in increasing its competitiveness.

The results of a study conducted by (SMEs Development Department, 2016) on "Mapping and Strategy for Increasing SMEs Competitiveness in

Facing the 2015 ASEAN Economic Community (AEC) and Post 2025 AEC. The results of the study indicate that innovation is a factor that can increase competitiveness. Furthermore (Nadia et al., 2016) with the research titled "Innovation and Competitive Advantage: Moderating Effects of Age in Foods Manufacturing SMEs in Malaysia". This study aims to examine the effect of innovation on competitive advantage in the food industry SMEs in Malaysia. The research findings reveal that innovation has a strong positive influence on competitive advantage. The results also state that SMEs must invest in innovation to gain competitive advantage. This study also found the effect of innovation by being moderated by the age of the company against competitive advantage.

Innovation is a key business factor because it has an impact on competitiveness (performance). Companies that are able to carry out innovations appropriately will be able to survive and grow in situations of intense competition and competitiveness. Innovation can create value for customers and companies (Terziowski, 2007). According to the OECD (2001), innovation is a factor that can increase competitiveness. While according to Kuratko & Howard Frederick (2016) in addition to economic drivers and economic efficiency, innovation is a factor that can drive a company's competitiveness. Nadia et al., (2016) research reinforce this opinion with the results of his research that innovation has a strong positive influence on competitiveness in the food industry SMEs in Malaysia. Chursin & Vlasov (2017) mentions that innovation is the basis for competitiveness. The higher the innovation that can be created by a company, the higher the competitiveness. The hypothesis in this study is that innovation affects competitiveness.

Based on the study of theory and the study of previous research, the conceptual framework of the study can be described as follows:

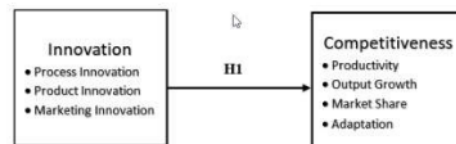

Fig. 1. Conceptual Framework

III. METHODS

A. Definition of Operational Variables

The dependent variable in this study is competitiveness, namely that a country gains a competitive advantage if the company in that country is competitive, capable of generating sustainable and growing profits adapted from Porter (1990), and Joewono (2006). Indicators of this variable are productivity, output growth, market share, and

adaptability (Man, et al (2002; UNIDO 2004; Tenai et al. 2009; Chong 2008).

The independent variable in this research is innovation, namely applying new ideas or ideas into a product or process and services produced by the company (Kotler and Keller, 2009; Chursin & Vlasov, 2017; Terziovski (2007). The indicators used are product innovation, process innovation, and marketing innovation (Hilmi, et al. 2010; Thomas, et al. 2011).

B. Sample and Data Collection

The type of research conducted in this study is quantitative research. The sampling technique was proportional random sampling for SMEs in the craft industry in West Java. To obtain the required data is to use a field research method (survey) by distributing questionnaires directly to respondents. The questionnaire was made based on the variables revealed to be indicators, from the indicators derived to the items in question. Each variable in this study has been tested in advance for the level of validity and reliability. Questionnaires are also equipped with answers in a structured form using the Likert Scale distance numbers from 5 to 1 which contain the following meanings:

- 5 = Always / Very High / Very Strong
- 4 = Often / High / Strong
- 3 = Sometimes / Moderate / Strong enough
- 2 = Rarely / Low / Weak
- 1 = Never / Very Low / Very Weak

C. Data Analysis Technique

The data collected will be analyzed with a quantitative approach with the aim of testing the hypothesis. The data analysis technique used in this study is the structural equation model (SEM) approach. The use of SEM allows researchers to test the validity and reliability of research instruments, confirming the accuracy of the model while testing the effect of innovation variables on competitiveness variables. The statistical tool used in this study is the AMOS version 23 program.

IV. RESULTS AND DISCUSSION

A. Descriptive analysis

Descriptive analysis is done to get an overview of the respondents which includes; gender, age of the owner, final education, and length of time to run a business. A general description of the characteristics of respondents in the study is presented in Table 1 below

TABLE 1. RESPONDENTS CHARACTERISTICS

No.	Characteristics	Prequency	Percentage (%)
1	Gender :		
	Male	160	78,05
	Female	45	21,95

2	Age of Owner :		
	Under 25	37	18,05
	26 - 50	107	52,19
3	Education :		
	Doctorate Degree	-	-
	Master Degree	2	0,98
	Bachelor Degree	11	5,37
	Senior High School	125	60,98
	Junior High School	37	18,05
4	Business Period :		
	0 - 5 years	21	10,24
	5 - 10 years	40	19,51
	11 - 15 years	51	24,88
	15 - 20 years	49	23,90
	20 - 25 years	27	13,17
	Above 25 years	17	8,29

Source: Data Processing Results (2018)

B. Validity Test

The results of the validity test for the instrument are shown in table 2 below:

TABLE 2. VALIDITY TEST RESULTS

Latent Variable	Manifest Variable	λ	Critical Point	Information
Innovation	X1	0,774	0,5	Valid
	X2	0,750	0,5	Valid
	X3	0,707	0,5	Valid
Competitiveness	Y1	0,704	0,5	Valid
	Y2	0,733	0,5	Valid
	Y3	0,763	0,5	Valid
	Y4	0,678	0,5	Valid

Source: Research Data (2018)

Based on the table above it can be seen that all indicators (manifest variable) have a factor loading (λ) ≥ 0.5 , this shows all indicators on each construct (latent variable) valid/significant.

C. Reliability Test

The reliability test results for the instruments are shown in table 3 below:

TABLE 3. RELIABILITY TEST RESULTS

Latent Variable	Manifest Variable	λ	λ^2	e	CR	VE	Information
Innovation	X1	0,774	0,599	0,401	0,788	0,554	Reliable
	X2	0,750	0,563	0,438			
	X3	0,707	0,500	0,500			
Competitiveness	Y1	0,704	0,650	0,496	0,811	0,519	Reliable
	Y2	0,733	0,830	0,537			
	Y3	0,763	0,766	0,582			
	Y4	0,678	0,692	0,460			

Source: Research Data (2018)

Based on the table above can be seen if the construct (latent variable) has a value of CR ≥ 0.7 and VE value ≥ 0.5 can be said to be reliable. Based on the

table, it can be seen that all constructs (latent variables) can be said to be reliable.

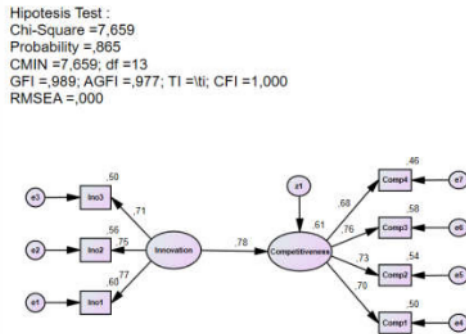

Fig. 2. Measurement and Structural Models

D. Hypothesis Test

Hypothesis testing is done by analyzing regression weight significance values to determine the effect of innovation on the competitiveness of SMEs in the craft sector. The basic decision-making test of significance for regression weight is:

- If p-value <math> < 0.05 </math> then the hypothesis becomes zero (0) and H_0 is rejected, meaning there is an influence between two variables statistically.
- If p-value > 0.05, the hypothesis becomes zero (0) and H_0 is accepted, meaning that there is no influence between the two variables statistically.

TABLE 4. REGRESSION WEIGHTS

		Estimate	S.E	C.R.	P	Label
Competitiveness	Innovation	.575	.077	7.486	***	

Based on the results of the study, it is known that the influence of innovation on competitiveness has a CR value of 7.486 and a value of $p < 0.05$, so H_0 is rejected and H_a is accepted, meaning that there is a positive and significant influence between innovation and competitiveness. The results of this study are in accordance with the opinion of Kuratko & Howard Frederick (2016), that innovation is a factor that can drive a company's competitiveness. OECD (2001) reinforces this opinion that innovation is a factor that can increase competitiveness. The results of this study also support the research conducted by Nadia et al., (2016) with the results of his research that innovation has a strong positive influence on competitiveness in the food industry SMEs in Malaysia.

V. CONCLUSION

Based on the sample size of 205 SMEs in the Handicraft sector, this study discusses the relationship between competitiveness and competitiveness in the craft sector SMEs in Indonesia. The findings reveal

that conversations about positivity are significant for competitiveness. The results of this study are in accordance with the theory of Kuratko & Howard Frederick (2016), which is a fact that can drive a company's competitiveness. In accordance with the theory of Chursin & Vlasov (2017), Terziopski (2007), and according to the OECD (2001), which refers to innovation as the basis for achieving competitiveness. The findings also support the results of research from Nadia et al. (2016) with the results of their research, namely that innovation has a positive power on competitiveness in SMEs. So, this studio shows the factors that are the determining factor because of the company's competitiveness.

Based on the results of these studies, the recommendations given are that craft-specific SMEs must support to create products, processes, and marketing continuously properly. SMEs must change the market done, can be adjusted when innovating.

ACKNOWLEDGMENT

I want to say thanks so much to Lembaga Pengelola Dana Pendidikan Indonesia (Indonesia Endowment Fund for Education) that supported and funded this research work. I also convey my gratitude to my supervisors that guide and support me for the publication of this article.

REFERENCES

- [1] Casson Mark, (2010). Entrepreneurship Theory, Networks, History, Edward Elgar Publishing, Inc. William Pratt House 9 Dewey Court Northampton Massachusetts 01060 USA.
- [2] Chursin, A., & Makarov, Y. (2015). Management of Competitiveness, Springer.
- [3] Chursin, A., & Vlasov, Y. (2017). Innovation as a Basis for Competitiveness, Theory, and Practice, Springer International Publishing, Switzerland.
- [4] Creswell, John, W. (2014). Research Design, Qualitative, Quantitative, and Mixed Methods Approaches, Fourth Edition, Sage Publications, Inc.
- [5] MSMEs Development Department, Indonesian Central Bank (2016). Mapping and Strategy for Increasing MSMEs Competitiveness in Facing the ASEAN Economic Community (AEC) 2015 and Post-MEA 2025.
- [6] Drucker, P. F. (2006). Innovation And Entrepreneurship : Practice and Principles. Harper Paperbacks.
- [7] Gronum, S., Verreynne, M., & Kastle, T. (2012). Medium-Sized Enterprise Innovation and. Journal of Small Business Management, 50(2), 257–282.
- [8] Hubert Osterle, Eigar Fleisch, Rainer Alt, (2001) Business Networking, Shaping Collaboration Between Enterprises, Second, Revised and

- Extended Edition, Springer-Verlag Berlin Heidelberg GmbH
- [9] Joewono, Handito, Hadi (2006), *7n1 Strategy Toward Global Competitiveness*, Seri Manajemen, Pustaka Bisnis Indonesia dan Arrbey.
- [10] Kuratko, D. F., & Howard Frederick, A. O. (2016). *Entrepreneurship, Theory/Process/Practice*, 4th Edition, Cengage Learning, Australia.
- [11] Metekohy, S. (2013). *The Effect of Resource-Based Strategy and Entrepreneurial Orientation on Competitive Advantages of Small Businesses and Micro Enterprises (Study of Maluku Ethnic Services)*, 12.
- [12] Nabi, I., & Luthria, M. (2002). *Building Competitive Firms: Incentives and Capabilities*, The World Bank, Washington DC.
- [13] Nadia, N., Aziz, A., & Samad, S. (2016). *Innovation and Competitive Advantage: Moderating Effects of Firm Age in Foods Manufacturing SMEs in Malaysia*, 35(October 2015), 256–266. [https://doi.org/10.1016/S2212-5671\(16\)00032-0](https://doi.org/10.1016/S2212-5671(16)00032-0)
- [14] OECD. (2001). *Enhancing SME Competitiveness*, The OECD Bologna Ministerial Conference.
- [15] Schwab, K. (2010). *The Global Competitiveness Report*. World Economic Forum.
- [16] Schwab, K., & Forum, W. E. (2017). *The Global Competitiveness Report*.
- [17] Suryana, 2013, *Entrepreneurship Practical Guidelines on Tips and Processes to Success*, Salemba Empat, Jakarta.
- [18] Terziovski, M. (2007). *Building Innovation Capability In Organizations: An International Cross-Case Perspective*. Imperial College Press.
- [19] Thomas, Brychan, Miller, Christopher, Murphy, Lyndon, (2011), *Innovation and Small Business, Volume 1*, Ventus Publishing ApS.
- [20] Widarjono, Agus. (2015). *Applied Multivariate Analysis with SPSS, AMOS and SmartPLS Programs*, Publishers UPP STIM YKPN, Yogyakarta.

THE EFFECT OF INNOVATION ON BUSINESS COMPETITIVENESS OF SMALL AND MEDIUM ENTERPRISE IN INDONESIA

ORIGINALITY REPORT

17%

SIMILARITY INDEX

9%

INTERNET SOURCES

7%

PUBLICATIONS

10%

STUDENT PAPERS

PRIMARY SOURCES

- 1** Susanti S Irma, B W H E Prasetyono, A R Siregar, N Ali, Dahniar. "Interrelationship development model of farmers with small scale feed mill", IOP Conference Series: Earth and Environmental Science, 2019
Publication 2%
- 2** Submitted to Stefan cel Mare University of Suceava
Student Paper 1%
- 3** Submitted to Northcentral
Student Paper 1%
- 4** Submitted to Chester College of Higher Education
Student Paper 1%
- 5** Submitted to School of Business and Management ITB
Student Paper 1%
- 6** Submitted to Touro College
Student Paper 1%

7	repository.unika.ac.id Internet Source	1 %
8	Submitted to Nyenrode Business Universiteit Student Paper	1 %
9	qlkh.humg.edu.vn Internet Source	1 %
10	admin.calitatea.ro Internet Source	1 %
11	Submitted to University of Ulster Student Paper	1 %
12	www.joams.com Internet Source	1 %
13	www.neliti.com Internet Source	1 %
14	Submitted to OTHM Qualifications Student Paper	1 %
15	"Innovation and Marketing Strategy for Batik Products In The Industrial Age 4.0", International Journal of Recent Technology and Engineering, 2019 Publication	1 %
16	telos-eu.com Internet Source	1 %
17	repository.unismabekasi.ac.id Internet Source	1 %

Exclude quotes On

Exclude matches < 1%

Exclude bibliography On